

PRODUCT FEATURES

- Type 3, Class 6, 60W PoE PD Module
- Very high efficiency (93%)
- 12V and 24V DC output voltage models
- Compact Size 60mm x 14mm
- Output power up to 60 Watts
- Support for Phihong 12.5K Ω signature
- Continuous output short circuit and overload protection¹
- In-built auxiliary wall adapter support
- Maintain Power Signature (MPS) for low power operation
- Low output ripple and noise
- Low electromagnetic interference (EMI)
- IEEE802.3bt Auto-class function support
- Highly efficient 1500V isolated DC-DC converter
- Infomart “design-in” assistance

PRODUCT OVERVIEW

The PEM6300BT is the world’s smallest 60 watts IEEE802.3bt PoE Powered Device (PD) module solution in its class. It is a low-cost solution compliant with the IEEE802.3bt Power over Ethernet (PoE) standard, with full backward compatibility to IEEE802.3at and IEEE802.3af standards. The module presents a Type 3, Class 6 PD signature and supports output power of up to 60W when powered by an IEEE802.3bt compliant Power Sourcing Equipment (PSE) capable of delivering the required power.

The PEM6300BT provides advanced features typically not available in standard PoE PD modules. These include Maintain Power Signature (MPS) to maintain connection to a compliant PSE during low-power operation, Auto-class for automatic power budgeting, and in-built support for automatic switchover to an external DC power source, such as a wall adapter. The module also provides power class and PSE type indications for system monitoring and control. It delivers a well-regulated, low-noise, and low-ripple output, and includes overload protection, output short-circuit protection, and inrush current protection.

The PEM6300BT is available in 12V and 24V output voltage variants. It features a low-EMI, highly efficient isolated DC-DC converter achieving efficiencies of up to 93%, while maintaining 1500V safety isolation between the input and output.

APPLICATION AREAS

- Thin Client computers, LED intelligent lighting
- Security and alarm systems
- High power Pan-Tilt-Zoom (PTZ) IP video surveillance cameras
- LCD displays, video panels, kiosks, Network monitors
- Thin clients and Single board computers
- Small computers, Digital Signage
- Public address systems
- 802.11n wireless, mesh networks, Bluetooth access points
- Environmental control, sensors, transducers and telemetry
- Industrial control and automation

¹ If the maximum power is exceeded, Module will operate in overcurrent mode and will auto recover once the overload condition is removed.

Table of Contents

PRODUCT SELECTOR	3
INPUT CHARACTERISTICS	3
DC OUTPUT CHARACTERISTICS	3
ABSOLUTE MAXIMUM RATINGS	3
TYPICAL INPUT CONNECTIONS	4
OUTPUT CONNECTION	4
BLOCK DIAGRAM	4
PIN CONNECTIONS.....	5
INPUTS	5
WALL ADAPTOR (WAP) SUPPLY	5
MAINTAIN POWER SIGNATURE (MPS)	6
POWER LEVEL INDICATION.....	6
AUTO-CLASS	7
ISOLATION.....	7
OUTPUT VOLTAGE ADJUSTMENT.....	7
EFFICIENCY V/S OUTPUT POWER.....	8
THERMAL MANAGEMENT	9
THERMAL PAD DIAGRAM (ALL DIMENSIONS IN MM)	10
PHYSICAL PACKAGE (ALL DIMENSIONS IN MM).....	10
ESD AND SURGE PROTECTION	11
ROHS, REACH AND CONFLICT MINERALS COMPLIANCE	11
REVISION HISTORY.....	11

Table of Figures

Figure 1- Typical Input Connections	4
Figure 2- Output connection.....	4
Figure 3- Block Diagram	4
Figure 4- Wall Adaptor Supply.....	5
Figure 5- Power level indication connections to host-board	6
Figure 6- PEM6312BT Efficiency vs. Output power end to end	8
Figure 7- PEM6324BT Efficiency vs. Output power end to end	8
Figure 8- Thermal Performance profile at 51V DC input (without airflow or heatsinking or thermal pad).....	9
Figure 9- Thermal Performance profile at 51V DC input (with airflow, no heatsink, no thermal pad)	9
Figure 10- Thermal pad diagram.....	10
Figure 11- Mechanical Dimensions	10

PRODUCT SELECTOR²

Part Number	Marking	Output Voltage ³	Efficiency ⁴	Maximum Output Power
		(Volts DC)	(%)	(Watts)
PEM6312BT	12	12	93	54
PEM6324BT	24	24	93	54

INPUT CHARACTERISTICS

Parameter	Symbol	Min.	Typ.	Max.	Units
Input Voltage (V_{IN})	V_{IN}	42	55	57	Volts
Input Current (DC) ⁵	I_{IN}	0		1.4	A
Maximum Inrush Current	I_{PK}			1.80	A
Under Voltage Lockout	V_{UVLO}	39		42	Volts
Operating Temperature	T_{OP}	-20		70	°C
IEEE 802.3bt Classification	Type 3 Class 6				

DC OUTPUT CHARACTERISTICS

Parameter	Symbol	Min.	Typ. ⁴	Max.	Units
Line Regulation	V_{LNRG}		0.1%		%
Load Regulation	V_{LDRG}		0.2%		%
Output Ripple and Noise	V_{RIP}		100	150	mV
Isolation Voltage (DC)	V_{ISOL}			1500	V
Temperature Coefficient	TC		100	300	ppm/°C
Output Short Circuit Duration				∞	Sec

ABSOLUTE MAXIMUM RATINGS

Supply Voltage (V_{CC})	0V ~ 57V DC
Input Current (A)	2A
Storage Temperature (T_S)	-25°C ~ +100°C
Output Voltage (V_{OUT})	0V to controlled output voltage (operating or non-operating)

² All specifications are generally provided at an ambient temperature T_A of 25°C, with a standard input voltage and rated output current, unless otherwise stated. These values are intended as design guidance only and are indicative, not guaranteed.

³ Output voltage is typical $\pm 3\%$ at a T_A of 25°C with nominal input voltage and rated output current.

⁴ Typical values are measured at nominal V_{IN} with >75% load at a T_A of 25°C output load.

⁵ Please refer to IEEE802.3af / 802.3at / 802.3bt standards documentation. Maximum input and inrush current are dependent on the assigned power class.

TYPICAL INPUT CONNECTIONS

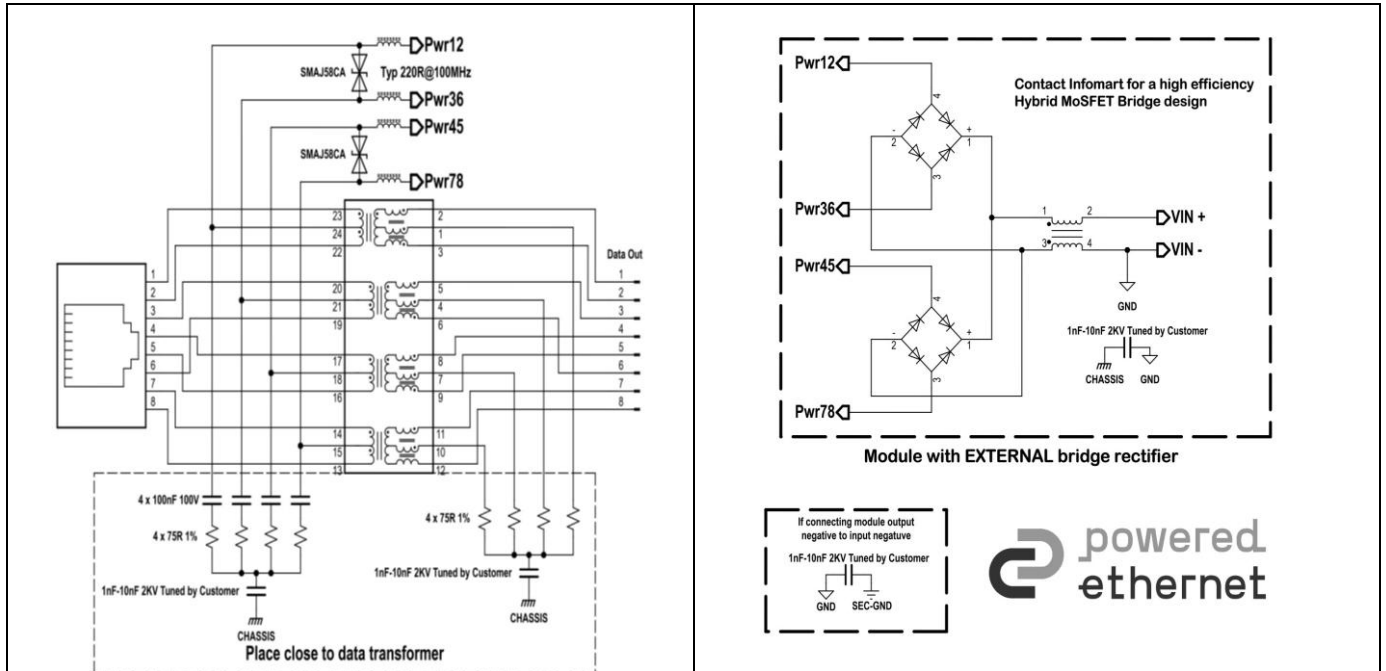

Figure 1- Typical Input Connections

OUTPUT CONNECTION

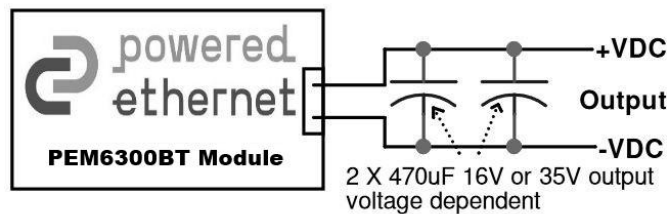

Figure 2- Output connection

BLOCK DIAGRAM

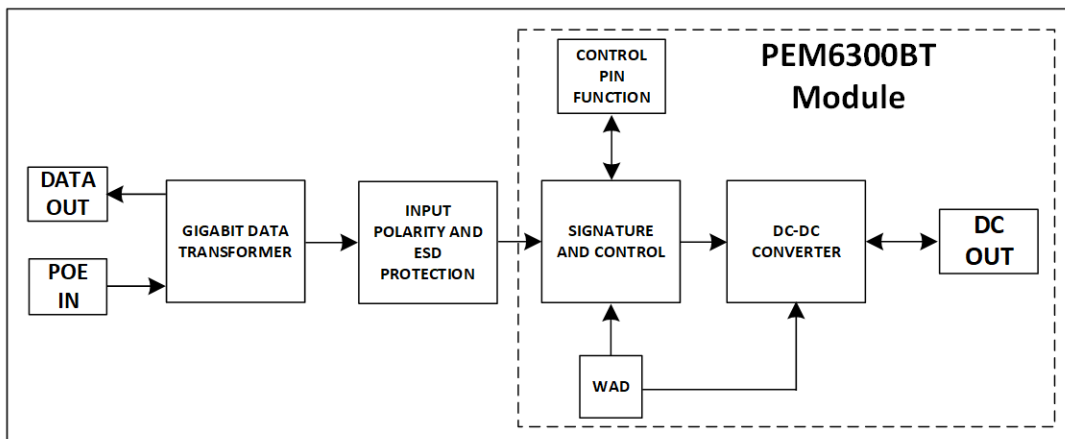

Figure 3- Block Diagram

PIN CONNECTIONS

INPUT PINS	
1,2	VIN+ . Connects to the positive (+) output of the input bridge rectifiers.
3,4	VIN- . Connects to the negative (-) output of the input bridge rectifiers and the wall adapter.
5,6	WAP . Connect to the positive (+) output of the wall adapter. Refer to the <i>WALL ADAPTOR (WAP) SUPPLY</i> section for details.
7	MPS . Maintain Power Signature. Refer to the <i>MAINTAIN POWER SIGNATURE (MPS)</i> section for details.
8	WAS . Wall adapter signal, refer to the <i>WALL ADAPTOR (WAP) SUPPLY</i> section for details.
9	PL1. PL2. PSE Type and Power level Indicator. Refer to the <i>POWER LEVEL INDICATION</i> section for details.
10	
11	PBT . PSE Type and Indicator. Refer to the <i>POWER LEVEL INDICATION</i> section for details.
12	AUC . Auto Class configuration. Refer to the <i>AUTO-CLASS</i> section for details.
OUTPUT PINS	
13, 14	-VDC . Output negative. Internally connected, must be connected together on the target motherboard.
15	OADJ . The output voltage can be adjusted from its nominal value. Refer to the <i>OUTPUT VOLTAGE ADJUSTMENT</i> section for details.
16, 17	+VDC . Output positive. Internally connected, must be connected together on the target motherboard.
To maintain isolation integrity, always connect respective input and output poles only via X or Y safety capacitors. Maintain the isolation barrier on the motherboard PCB as specified in the <i>PHYSICAL PACKAGE (ToI. ±0.50mm)</i>.	

INPUTS

The PEM6300BT is designed to be powered by an IEEE802.3bt compliant PSE capable of delivering the required power, or by an auxiliary external DC power supply such as a wall adapter. When powered by a PSE, the system designer must provide input polarity protection using bridges circuits on each input line (see *Figure 1- Typical Input Connections*). The bridges may be constructed using diodes or MoSFET H-Bridges or hybrid MoSFET-diode bridges. Please [contact Infomart technical support](#) for more information.

WALL ADAPTOR (WAP) SUPPLY

The PEM6300BT has built-in support for an auxiliary external DC power supply, such as a wall adapter. To achieve the module’s maximum power of 54W, we recommend an external supply with a minimum current rating of 2A and an output voltage between 51V and 55V. Connect the positive terminal of the external DC supply to the WAP pin via a diode, and the negative terminal to the VIN- pin. The PEM6300BT detects the voltage from the external DC supply and automatically switches to it when the input voltage exceeds 48V. If the voltage falls below 42V, the module will de-prioritize the external DC supply. When the external DC power is prioritized, all IEEE802.3bt/at/af related functions, such as Maintain Power Signature (MPS) and Auto-Class, will be turned off.

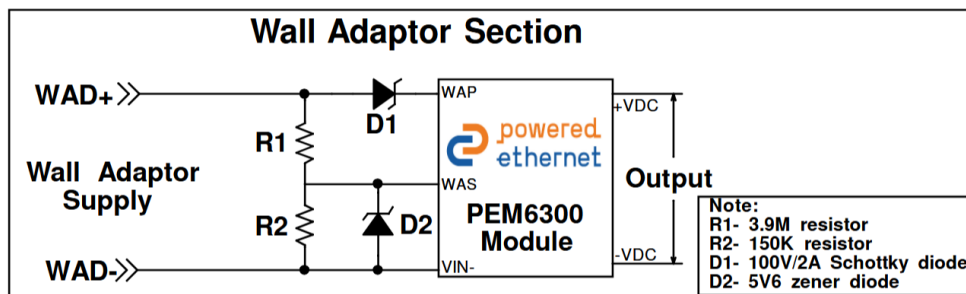

Figure 4- Wall Adaptor Supply

MAINTAIN POWER SIGNATURE (MPS)

The PEM6300BT module features a Maintain Power Signature (MPS) function, supporting applications that require low-power standby modes, in compliance with the IEEE802.3bt standard.

According to the IEEE802.3 PoE standard, a minimum current of 10 mA is required to prevent power disconnection from the Power Sourcing Equipment (PSE) during standby. The PEM6300BT automatically enters MPS mode when the input current drops below 16mA and exits this mode once the current exceeds 16mA, ensuring minimal power consumption while maintaining the connection to a compliant PSE.

The MPS function is enabled by default, with predefined duty cycles and current levels as specified in the table below.

PSE type	Duty Cycle	Ton	Toff	MPS current
3,4	8.1%	16ms	184ms	16mA

Table 1- Maintain power signature (MPS)

POWER LEVEL INDICATION

PL1, PL2, and PBT are open-drain, active-low output pins referenced to VIN- and are used to indicate the PD power class and the PSE type. PL1 and PL2 indicate the allocated power level, while the PBT pin indicates the type of PSE connected. If the PEM6300BT is connected to an IEEE 802.3bt compliant Type 3 or Type 4 PSE, the PBT pin will be asserted low. The PBT, PL1, and PL2 pins are reset to a high state upon a reset or power-down event.

Table 2- Power level indication provides complete details of the pin behaviour. To preserve the primary-to-secondary 1500V isolation, the system designer must use opto-isolators when connecting the PL1, PL2, and/or PBT pins to a host-board control device, such as a microcontroller. Please see Figure 5- Power level indication connections to host-board.

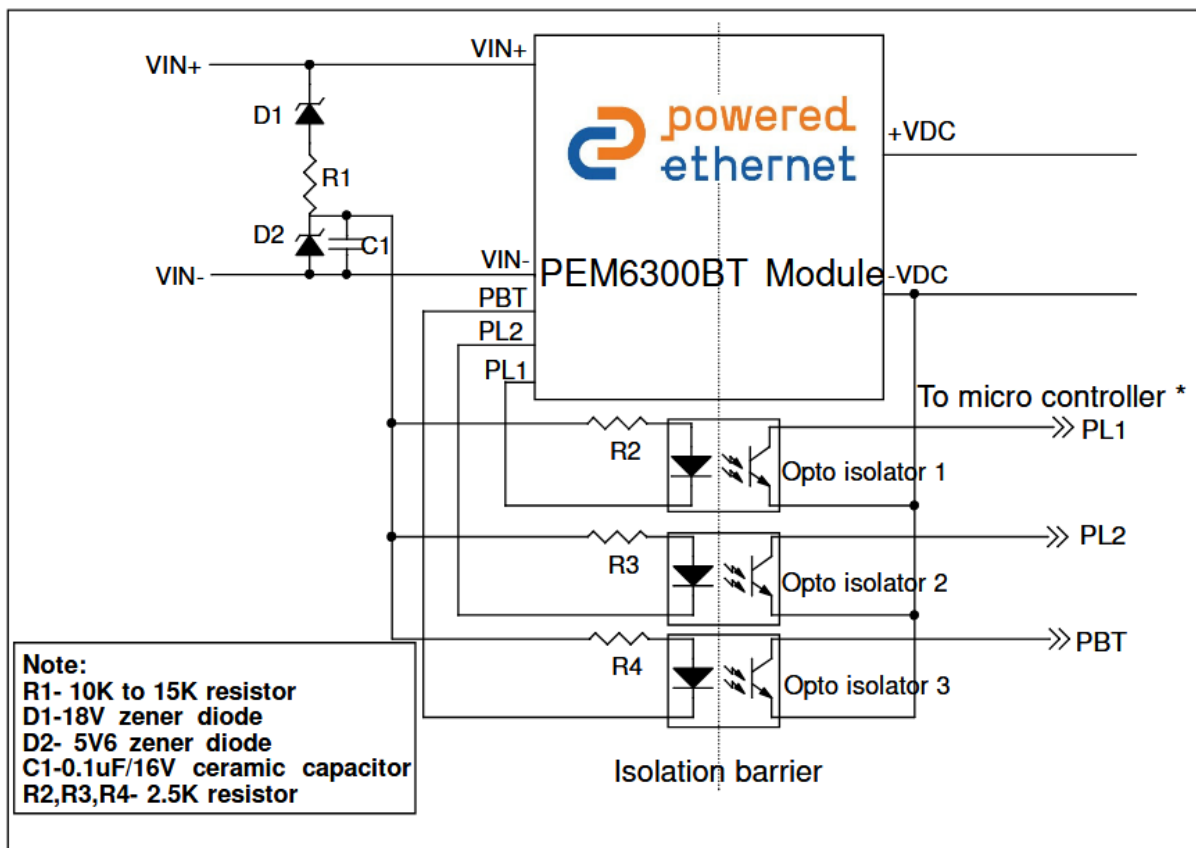

Figure 5- Power level indication connections to host-board

PSE Type	PD Class	Class Events	Minimum Requested Power(W)	PL1	PL2	PBT
1 or 2	0	1	12.95	High	High	High
1 or 2	1	1	3.84	High	High	High
1 or 2	2	1	6.49	High	High	High
1 or 2	3	1	12.95	High	High	High
2	4	2	25.5	Low	High	High
3 or 4	0	1	12.95	High	High	Low
3 or 4	1	1	3.84	High	High	Low
3 or 4	2	1	6.49	High	High	Low
3 or 4	3	1	12.95	High	High	Low
3 or 4	4	2 or 3	25.5	Low	High	Low
3 or 4	5	4	38.25	High	Low	Low
3 or 4	6	4	51	High	Low	Low
4	7	5	62	Low	Low	Low
4	8	5	71.3	Low	Low	Low

Table 2- Power level indication

AUTO-CLASS

Auto-Class is a mechanism introduced in the IEEE802.3bt standard that allows a Type 3 or Type 4 Powered Device (PD) to communicate its effective maximum power consumption to a Type 3 or Type 4 Power Sourcing Equipment (PSE). This enables the PSE to budget power efficiently. The PEM6300BT supports this feature, allowing Type 3 and Type 4 PSEs to optimize their power management. To enable Auto-Class on the PEM6300BT, connect the AUC pin to VIN-.

For more details please see [The benefits of using the Auto-class \(AUC\) feature in IEEE802.3bt PoE.](#)

ISOLATION

The IEEE802.3af/at/bt standards requires that a Powered Device (PD) meet safety isolation requirement by passing the electrical strength test specified in IEC 60950, sub-clause 6.2. The PEM6300BT module complies with these requirements by meeting or exceeding the 1500V impulse test, commonly referred to as the "Hi-Pot Test," or "Isolation Test Voltage".

The "keep-out area" shown in *Figure 11- Mechanical Dimensions* indicates the location and size of the electrical isolation barrier. This area must be kept clear of PCB tracks (traces) or planes on the base PCB on which the PEM6300BT is mounted to ensure compliance with the isolation requirements.

OUTPUT VOLTAGE ADJUSTMENT

The PEM6300BT series features an OADJ pin that allows the output voltage to be adjusted from its nominal value. This adjustment is achieved by connecting a resistor with a minimum power rating of 1/16 W and a tolerance of 1% between the OADJ pin and either the +VDC pin or the -VDC pin, as specified in the relevant table. Only one connection is permitted at a time either between OADJ and +VDC or between OADJ and -VDC. The output voltage must not be adjusted by more than $\pm 10\%$ or $\pm 1.5V$ (whichever is lower) from the nominal value to ensure safe and reliable operation. All voltage measurements should be taken at the output pins of the module. An estimated resistance value for voltage adjustment is provided below. Customers should fine-tune the most appropriate resistance value as required.

Please [contact Infomart technical support](#) for more details or specific resistor values.

PEM6312BT			PEM6324BT		
Output Voltage	OADJ to +VDC	OADJ to -VDC	Output Voltage	OADJ to +VDC	OADJ to -VDC
11V	34.8KΩ		22V	83.5KΩ	
11.5V	64.9KΩ		22.99V	152KΩ	
12V	DNP	DNP	24V	DNP	DNP
12.50V		32.4KΩ	24.99V		38.3KΩ
13V		13.7KΩ	25.99V		15KΩ

Table 3- Output Voltage Adjustment

EFFICIENCY v/s OUTPUT POWER⁶

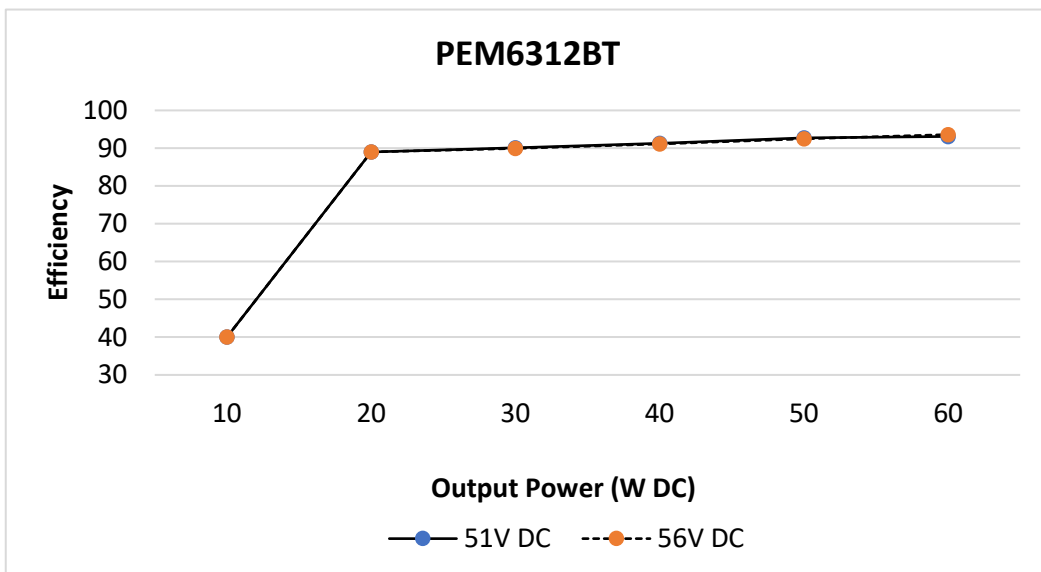

Figure 6- PEM6312BT Efficiency vs. Output power end to end

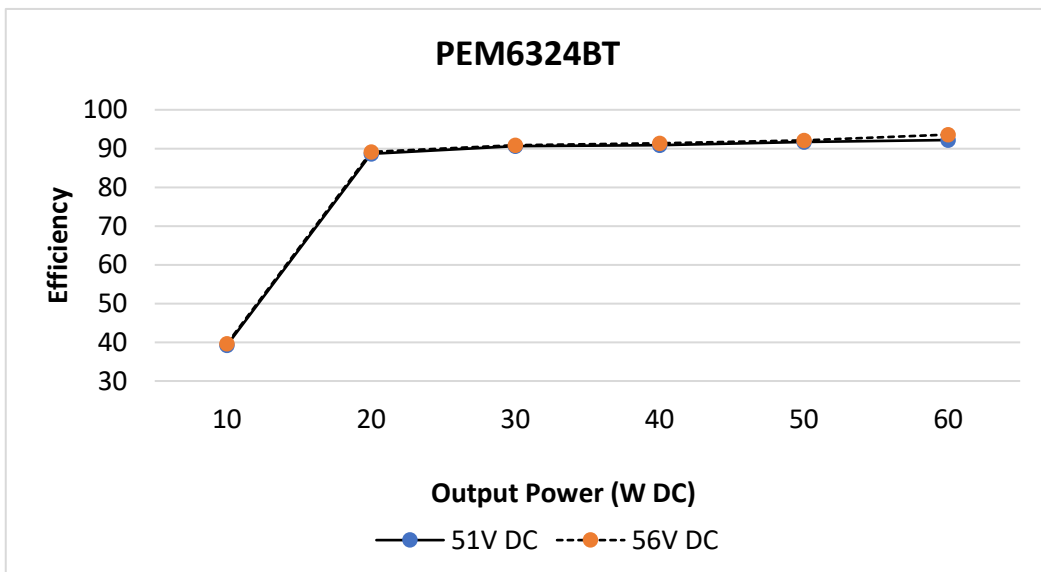

Figure 7- PEM6324BT Efficiency vs. Output power end to end

⁶ Product use must comply with the specified input and output characteristics and must not exceed the absolute maximum ratings.

THERMAL MANAGEMENT

The PEM6300BT boards generate heat during operation. To ensure optimal performance and reliability, adequate ventilation and airflow must be considered during the design phase. The amount of heat generated by the PEM6300BT depends on the output power being drawn. *Figure 8* illustrates the thermal performance of the PEM6300BT with a 51V DC input under still-air conditions, without the use of additional thermal pads, heat sinking, or forced airflow.

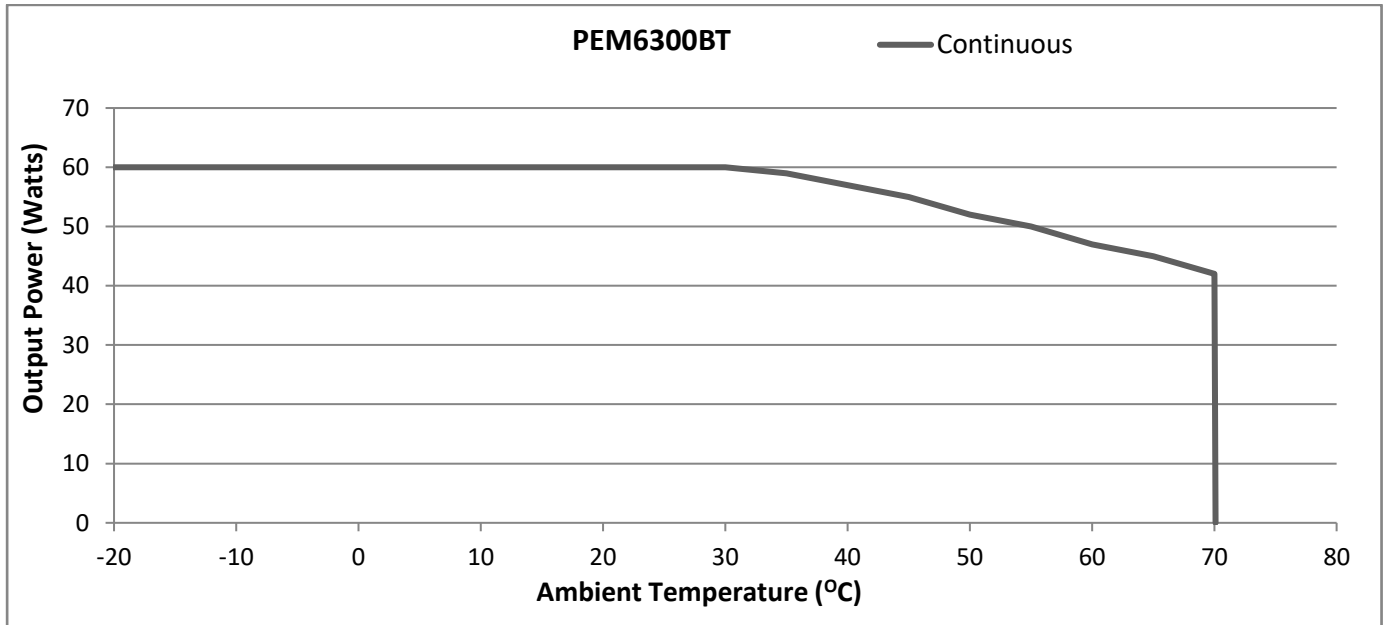

Figure 8- Thermal Performance profile at 51V DC input (without airflow or heatsinking or thermal pad)

To enhance thermal performance, a combination of forced airflow over the module and/or heat sinking using the mounting holes and/or thermal pad materials from suppliers such as 3M, Würth, Bergquist, or Aavid, etc. can be implemented to maintain the module within safe operating temperatures. When using the mounting holes, the system designer must ensure that the 1500V primary-to-secondary isolation is maintained.

The PEM6300BT can handle up to 60W at an ambient temperature of 70°C with a continuous airflow of 9cfm without the use of a thermal pad or heatsinking. The thermal performance with just airflow is illustrated in the *Figure 9* below.

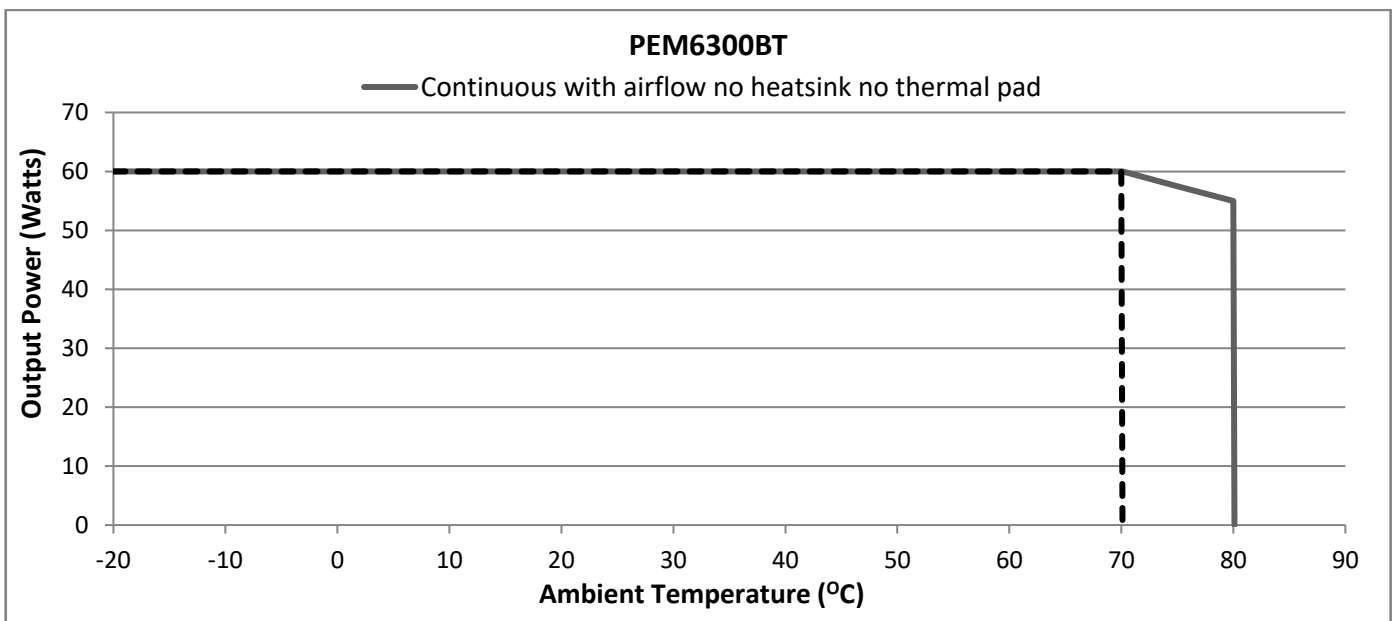

Figure 9- Thermal Performance profile at 51V DC input (with airflow, no heatsink, no thermal pad)

THERMAL PAD DIAGRAM

A power-plane heat sink on the motherboard is a relatively simple method to draw heat away from the PEM6300BT using the output pins (-VDC and +VDC), which are connected to a PCB heat sink on the motherboard. **It is important to maintain electrical isolation between the OADJ pin and the +VDC and -VDC pins to ensure proper output voltage regulation.**

Thermal performance can be improved by applying forced airflow over the module and by using a heat sink (a) glued to the diodes using thermal adhesive, or (b) implemented as a power-plane heat sink, as described below. These two methods can also be combined for improved thermal management

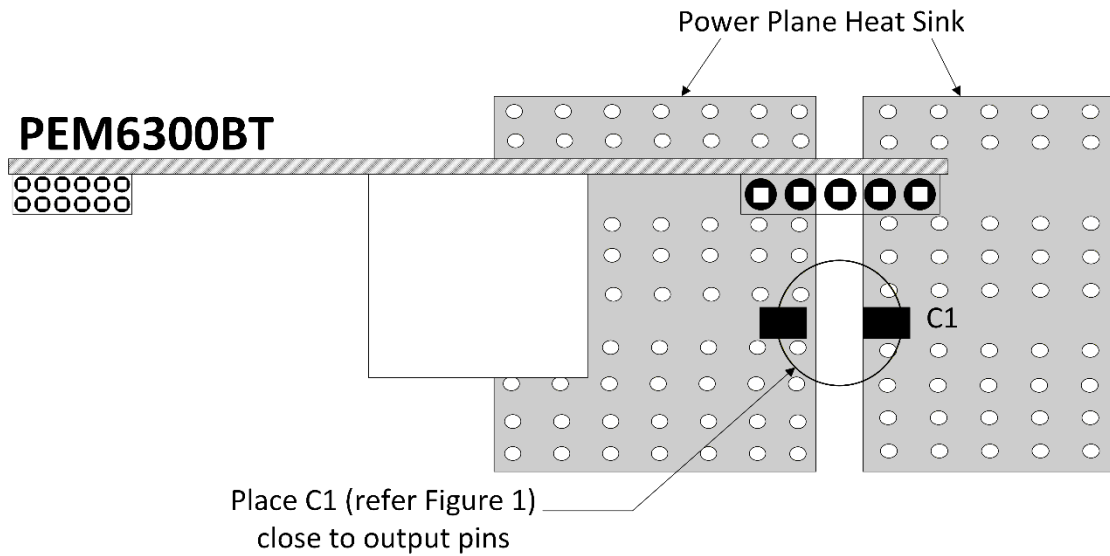

Figure 10- Thermal pad diagram

PHYSICAL PACKAGE (Tol. ±0.50mm)

All dimensions in mm and nominal unless stated otherwise

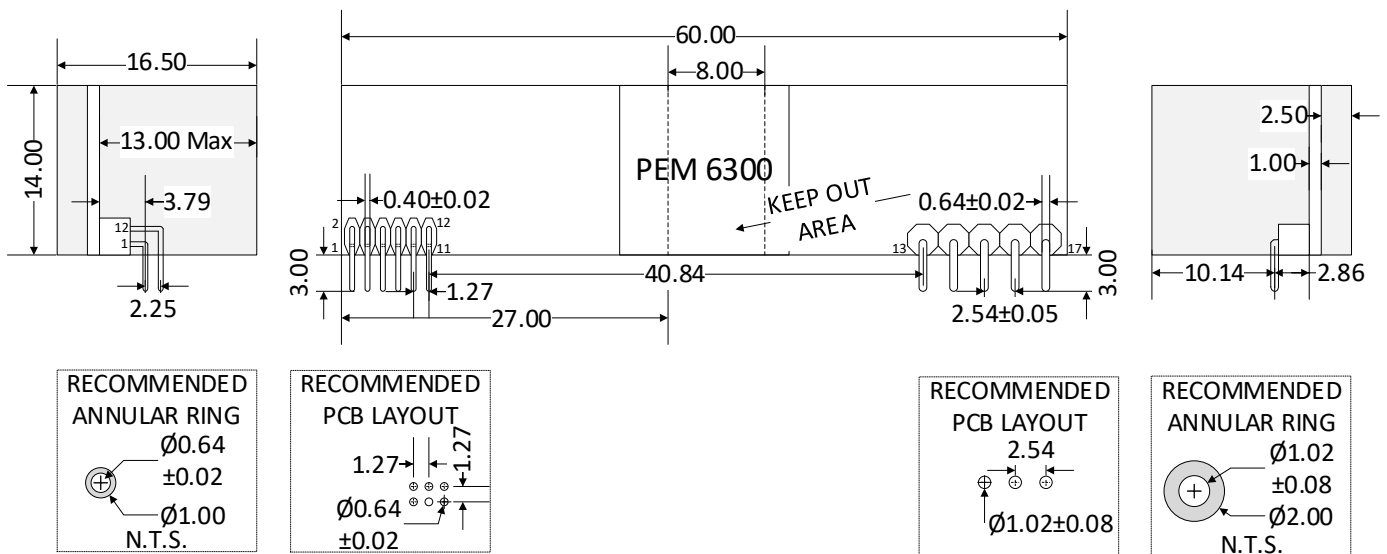

Figure 11- Mechanical Dimensions

ESD AND SURGE PROTECTION

System designers must implement Electrostatic Discharge (ESD) and surge protection at the input of the PEM6300BT to prevent damage from over-voltage events and ensure compliance with EMC and ESD standards. This can be achieved using a TVS diode, such as the SMAJ58A (uni-directional) or SMAJ58CA (bi-directional). These diodes effectively clamp voltage spikes, protecting the module and improving overall system reliability.

ROHS, REACH and CONFLICT MINERALS COMPLIANCE

ROHS, REACH, and Conflict Minerals compliance details are available on our website www.poweredethernet.com.

REVISION HISTORY

REVISION NUMBER	DESCRIPTION
25LR1	▪ New release

IEEE802.3 POWER LEVELS AND CLASSES

IEEE Standard	Common Name	PD Class	PD/PSE Type	Max num. Of events	PD Power ¹	PSE Power ²	Wire pairs energised	AUC ³
802.3af	POE	0	1	-	12.95W	15.4W	2	No Support
802.3af	POE	1	1	1	3.84W	4W	2	No Support
802.3af	POE	2	1	1	6.49W	7W	2	No Support
802.3af	POE	3	1	1	12.95W	15.4W	2	No Support
802.3at	POE+	4	2	2	25.5W	30W	2	No Support
802.3bt	POE++	5	3	4	38.25W	45W	4	Optional
802.3bt	POE++	6	3	4	51W	60W	4	Optional

¹ Min. power delivered to PD / Module input. Max. PD / Module output depends on operating conditions.

² Power delivered from the Power Sourcing Equipment (PSE) (switch or injector) at its output port.

³ Auto Class is supported. It is optional to enable or not.

by  INFOMART

IEEE802.3bt compliant type 3 Class 6 60W POE PD Module

**Infomart India Pvt. Ltd.**

Infomart Tech Park

99, 5th Cross, 5th Block, Koramangala

Bangalore – 560 095, India

Tel: +91 80 4111-7200

Email: pesales@infomartgroup.com**Infomart Technologies**

Americas Sales Office

5904, South Cooper St. #104-96

Arlington, Texas, 76017, USA

Tel: +1 903-270-9090

Infomart India Pvt. Ltd. (Infomart®) products are sold subject to the general terms and conditions of commercial sale, as published at www.poweredethernet.com unless otherwise agreed on a written agreement. Infomart® reserves the right to make changes to any products herein, without further notice. The customer is responsible for its products and applications using Infomart® products, including compliance with all laws, regulations and safety requirements or standards, regardless of any support or applications information provided by Infomart®. “Typical” parameters which may be provided in Infomart® data sheets and / or in specifications can and do vary in different applications and actual performance may vary over time. Infomart® makes no warranty, representation or guarantee regarding the suitability of its products for any particular purpose, nor does Infomart® assume any liability arising out of the application or use of any product or circuit, and specifically disclaims any and all liability, including without limitation special, consequential or incidental damages. All operating parameters, including “Typical” must be validated for each customer application by customer’s technical experts. Infomart® products are not designed, intended, or authorized for use as a critical component in life support systems or any FDA Class 3 medical devices or medical devices with a same or similar classification in a foreign jurisdiction or any devices intended for implantation in the human body. Should Buyer purchase or use Infomart® products for any such unintended or unauthorized application, Buyer shall indemnify and hold Infomart® or and its officers, employees, subsidiaries, affiliates, and distributors harmless against all claims, costs, damages, and expenses, and reasonable attorney fees arising out of, directly or indirectly, any claim of personal injury or death associated with such unintended or unauthorized use, even if such claim alleges that Infomart® was negligent regarding the design or manufacture of the part. This document is subject to all applicable copyright laws and is not for resale and may not be altered in any manner. Infomart is a registered trademark of Infomart® (India) Pvt. Ltd. PoweredEthernet™ is a trademark of Infomart (India) Pvt. Ltd.

