



PRODUCT FEATURES

- IEEE802.3bt PoE PD full Network Interface solution, no external components required
- Type 4, Class 8 PoE PD board upto 90W
- Highly efficient (93%) 1500V isolated DC-DC converter
- Compact Size 60mm x 80mm
- Maintain Power Signature (MPS) for low power
- 12V, 20V, 24V DC output voltage models
- Support for legacy Phihong 12.5K Ω signature
- Choice of PoE input and data output connectors
- Low output ripple and noise
- Infomart “design-in” assistance
- High temperature operation upto 80°C without heat sink or forced airflow
- Auto-class support for automatic power budgeting
- In-built primary side auxiliary wall adapter support
- Supports parallel Load sharing upto 240W
- 20V variant for USB-C power delivery
- Low electromagnetic interference (EMI)
- Integrated input ESD protection
- Output short circuit protection
- RJ45 & 9 pin wafer header connector options

PRODUCT OVERVIEW

The PEB9300BT series is a fully integrated, ready-to-use IEEE802.3bt Power over Ethernet (PoE) solution. It supports Type 4, Class 8 operation and delivers up to 90W of output power when powered by a compatible PoE Power Sourcing Equipment (PSE).

The PEB9300BT is fully compliant with the IEEE802.3bt PoE standard and is backward compatible with IEEE802.3af and IEEE802.3at standards.

The device integrates comprehensive protection features including under-voltage protection, over-temperature protection, and Maintain Power Signature (MPS) functionality to prevent unintended power disconnection from the PSE. Pins PL1, PL2, and PBT indicate the allocated power class and PSE type.

An advanced circuit topology enables high efficiency of up to 93%, providing well-regulated output voltage with low ripple and noise. Built-in protections include overload, output short-circuit, and inrush-current protection.

An optional auxiliary wall-adapter input allows detection of external DC power and provides seamless switchover from PoE to wall-adapter power when available.

APPLICATION AREAS

- Thin Client computers, LED intelligent lighting
- Security and alarm systems
- High power Pan-Tilt-Zoom (PTZ) IP video surveillance cameras
- LCD displays, video panels, kiosks, Network monitors
- 802.11n wireless, mesh networks, Bluetooth access points
- Small computers, Digital Signage
- Public address systems
- Environmental control, sensors, transducers and telemetry
- Thin clients and Single board computers
- Industrial control and automation

Table of Contents

PRODUCT SELECTOR	3
INPUT CHARACTERISTICS	3
DC OUTPUT CHARACTERISTICS	3
ABSOLUTE MAXIMUM RATINGS	3
BLOCK DIAGRAM	4
PIN CONFIGURATIONS	4
POE INPUT.....	5
WALL ADAPTOR (WAD) AUXILIARY SUPPLY	5
POWERED SIGNATURE CLASSIFICATION.....	5
MAINTAIN POWER SIGNATURE (MPS)	6
POWER LEVEL INDICATION.....	6
AUTO-CLASS FEATURE.....	7
ISOLATION.....	7
LOAD SHARING	7
THERMAL MANAGEMENT	8
PHYSICAL PACKAGE (ALL DIMENSIONS IN MM).....	9
ORDERING INFORMATION	9
ROHS, REACH AND CONFLICT MINERALS COMPLIANCE	10
REVISION HISTORY.....	10

Table of Figures

Figure 1- Block Diagram	4
Figure 2- Power Signature Classification	5
Figure 3- Power level indication connections to host-board	6
Figure 4- Load Sharing Control.....	8
Figure 5- Thermal Performance profile at nominal V_{in}	8
Figure 6- Mechanical Dimensions	9

PRODUCT SELECTOR¹

Part Number	Output Voltage ²	Efficiency ³	Maximum Output Power
	(Volts DC)	(%)	(Watts)
PEB9312BT	12	93	90
PEB9320BT	20	93	90
PEB9324BT	24	93	90

INPUT CHARACTERISTICS

Parameter	Symbol	Min.	Typ.	Max.	Units
Input Voltage (V_{IN})	V_{IN}	42	55	57	Volts
Under Voltage Lockout	V_{UVLO}	39		42	Volts
Input Current (DC) ⁴	I_{IN}	0		1.70	A
Maximum Inrush Current	I_{PK}			1.80	A
Operating Temperature	T_{OP}	-20		70	°C
802.3bt Power Classification	Type 4 Class 8				

DC OUTPUT CHARACTERISTICS

Parameter	Symbol	Min.	Typ ³	Max.	Units
Line Regulation	V_{LNRG}		0.1		%
Load Regulation	V_{LDRG}		0.2		%
Output Ripple and Noise	V_{RIP}		100	150	mV
Isolation Voltage (DC)	V_{ISOL}			1500	V DC
Temperature Coefficient	TC		100	300	ppm/°C
Output Short Circuit Duration				∞	Sec
Output Wire		20	18	16	AWG

ABSOLUTE MAXIMUM RATINGS

Supply Voltage (V_{CC})	0V ~ 57V DC
Input Current (A)	2A
Storage Temperature (T_S)	-25°C ~ +100°C
Output Voltage (V_{OUT})	0V to controlled output voltage (operating or non-operating)

¹ All specifications are typical at a T_A of 25°C with nominal input voltage and rated output current, unless otherwise noted. These are intended as a design aid only and are indicative, not guaranteed.

² Output is typically $\pm 3\%$ at a T_A of 25°C with a nominal input voltage.

³ Typical values are measured at nominal V_{IN} with >75% load at a T_A of 25°C.

⁴ Please refer to the IEEE802.3af / 802.3at / 802.3bt standards document. Maximum input and inrush current depend on the power class.

BLOCK DIAGRAM

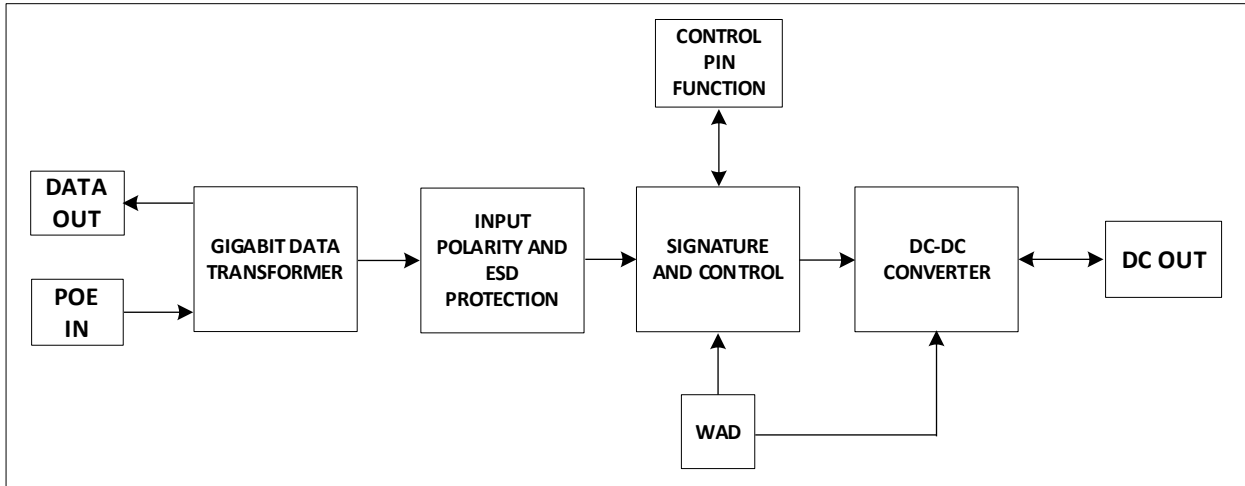

Figure 1- Block Diagram

PIN CONFIGURATIONS

Input Connectors:

PoE IN	RJ45 connector, Tab-Up / Optional alternate 9 pin Header with 1.25mm pitch ⁵
WAD	For models fitted with optional wall adapter support

Output Connector:

DATA OUT	RJ45 connector, Tab-Up / Optional alternate 9 pin Header with 1.25mm pitch
DC OUT	3 pin Terminal Block ⁶

Control and Indication Pins - J5 (1.27mm Header Block):

1, 2	SGA ENABLE: Short pins 1 and 2 using a 1.27mm jumper connector to provide a 12.5KΩ signature resistance required by certain legacy Phihong and other PSEs. Leave the pins open for all other PSEs.
3	PL1: PSE Type and Power level Indicator. Refer to the <i>POWER LEVEL INDICATION</i> section for details
4	PL2: PSE Type and Power level Indicator. Refer to the <i>POWER LEVEL INDICATION</i> section for details.
5	PBT: PSE Type and Indicator. Refer to the <i>POWER LEVEL INDICATION</i> section for details.
6	CGND: Control and Indication pins return path. Use with pins 3, 4 and 5 as needed.
7, 8	AUC ENABLE: Short pins 7 and 8 using with 1.27mm jumper connector to the enable Auto-class function. Refer to <i>AUTO-CLASS FEATURE</i> section for details.

Note:

- **J5** Block requires extreme precaution against ESD in handling
- Pin 9 of PoE IN and DATA OUT connectors is connected to the metal body of the RJ45 connectors. When using a header connector, Pin 9 must be connected to the chassis. Do not connect the Input grounds and Output grounds

⁵ Before ordering, check with Infomart for MOQ and availability

⁶ Ensure that the output wires have an adequate current rating of the unit's rated O//P current.

POE INPUT

The PEB9300BT is compliant with IEEE802.3bt and backward compatible with IEEE802.3af and IEEE802.3at Power Sourcing Equipment (PSE). It supports both 4-pair and data-pair power-injection methods and provides power-level indication. The PEB9300BT can accept up to 85W of input power and offers PoE input connectivity through either an RJ45 connector or an optional 9-pin header.

WALL ADAPTOR (WAD) AUXILIARY SUPPLY

PEB9300BT boards equipped with an optional auxiliary DC power input. DC power can be directly connected to the WAD pins. When the voltage at the WAD connector exceeds 48V, the PEB9300BT automatically detects the wall adapter and smoothly switches priority from PoE input to wall-adapter input. When wall-adapter power is detected, the internal isolation MOSFET is turned off, the PoE classification current is disabled (if VIN is within the classification range), and the Smart MPS comparator is disabled. The LED (WA) indicator lights up to confirm the activation of the wall adapter input.

Recommended WAD female connectors include Molex 22011022, Würth 61900211621, Protectron P9050H29-00-2, Adam Tech MTA-02, etc.,

POWERED SIGNATURE CLASSIFICATION

The PEB9300BT is a type 4, Class 8 PD that requests the highest nominal power level from an IEEE802.3bt PSE. When connected to an IEEE802.3at PSE, it will recognize the initial Class 4 pulse as a Type 2 PD and provide 25W.

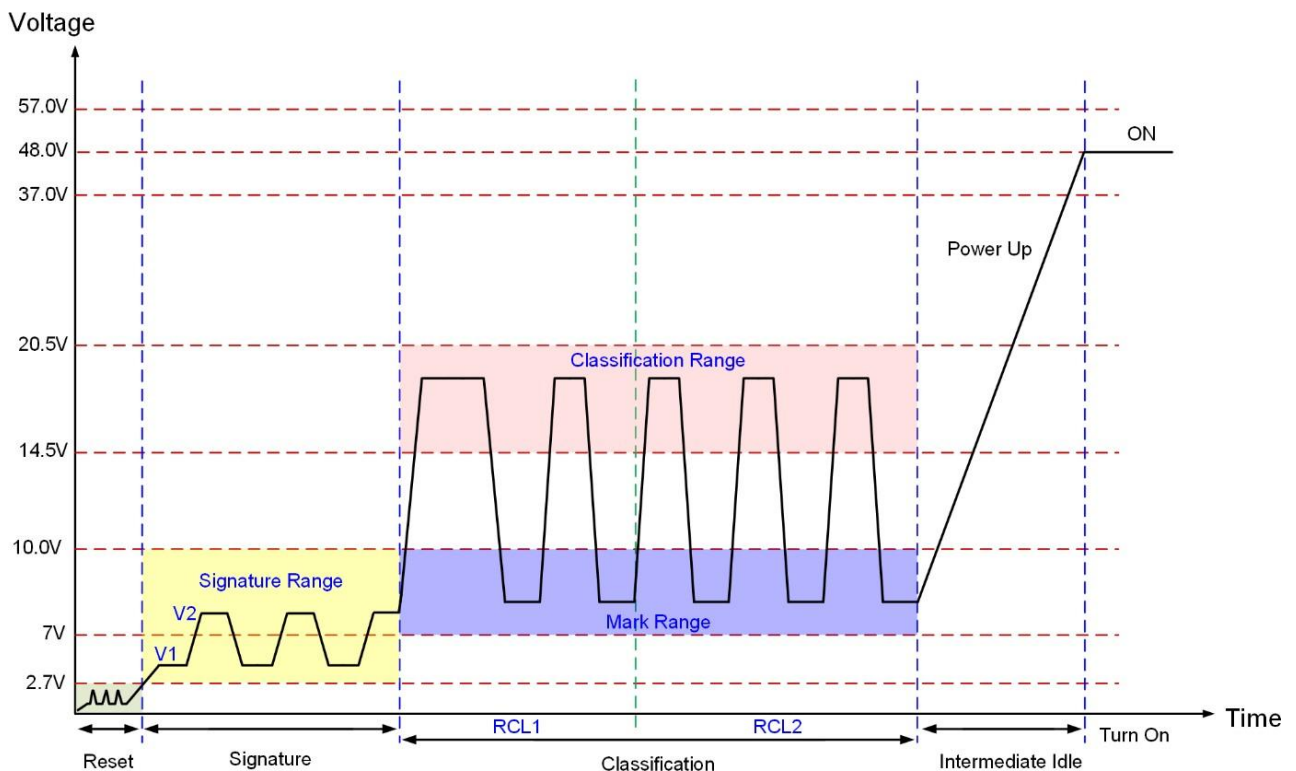

Figure 2- Power Signature Classification

Voltages V1 and V2 with minimum 1V differences are applied by the PSE to extract a signature value. At this time, the PD presents a load current determined by the resistances connected to the RCLASS pins (RCL1 and RCL2). After the PSE measures the PD load current, if it is a high-power PSE, it applies a mark voltage (6.9-10V) followed by a classification voltage (14.5-20.5V). The PD responds by presenting a load current as determined by RCL1 and RCL2. After the PSE measures the PD load current during several classification events and determines that it can deliver the requested power, it moves into the ON state by raising the voltage to approximately 48V for PoE BT power levels.

MAINTAIN POWER SIGNATURE (MPS)

The MPS feature is provided by the PEB9300BT, enabling applications that require low-power standby modes. The MPS current is generated in compliance with the IEEE802.3bt standard, allowing the PSE to maintain power during standby conditions. A minimum port current of 10mA can be maintained in MPS mode to prevent power disconnection from the PSE. To sustain PSE power in very low-current conditions, the PWM-PD controller generates a pulsed current that reaches the required threshold to maintain power.

The device automatically enters MPS mode when the port current falls below 16mA and exits MPS mode when the port current exceeds 16mA. The pulsed current amplitude and period are automatically selected based on the PSE type (1-2, 3-4), to maintain PSE power while minimizing power consumption.

PSE type	Duty Cycle	Ton	Toff	MPS current
3,4	8.1%	16ms	184ms	16 mA

Table 1- MPS feature

POWER LEVEL INDICATION

PL1, PL2, and PBT are open-drain, active-low output pins referenced to VIN- and are used to indicate the PD power class and the PSE type. PL1 and PL2 indicate the allocated power level, while the PBT pin provides an indication of the connected PSE type. If the PEB9300BT is connected to an IEEE802.3bt-compliant Type 3 or Type 4 PSE, the PBT pin will go low. The PBT, PL1, and PL2 pins are reset to high upon a reset or power-down event.

Two types of BT indications are provided: LED indications for easy identification of the power class and signal indications for communication with an MCU. The J5 control pins (3, 4, and 5) are used to communicate PSE type and power level information to the MCU.

Table 2- Power level indication provides complete details on the behaviour of these pins. To preserve the 1500V primary-to-secondary isolation, the system designer must use opto-isolators when connecting the PL1, PL2, and/or PBT pins to a host-board control device such as a micro-controller. Please see Figure 3- Power level indication connections to host-board.

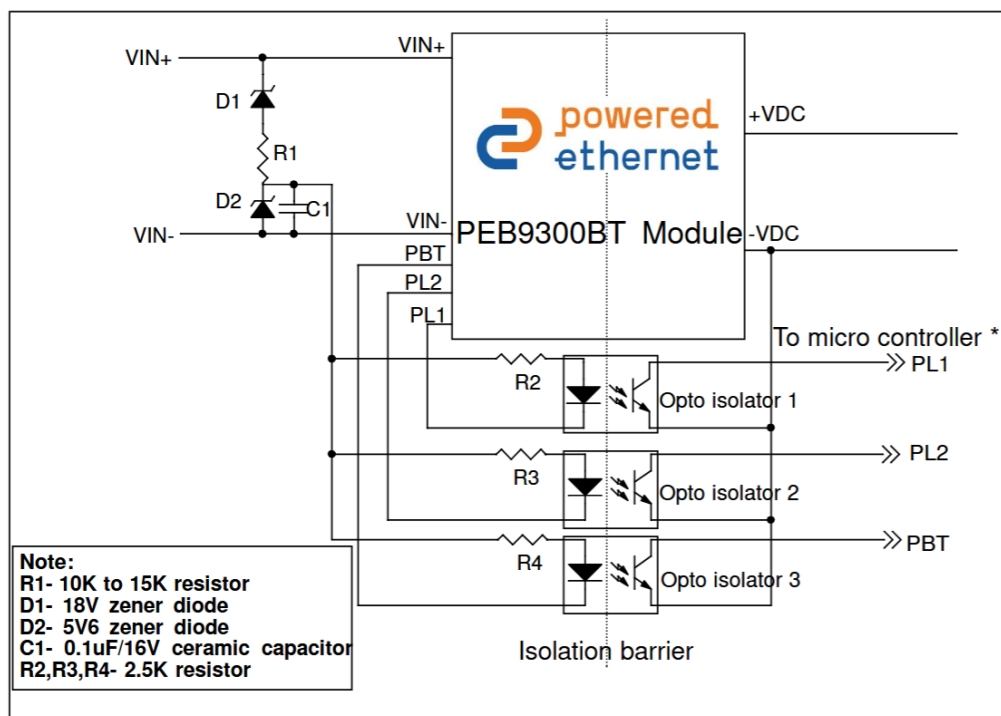

Figure 3- Power level indication connections to host-board

PSE Type	PD Class	Class Events	PSE available power(W)	PL1		PL2		PBT	
				J5-3	P1 (LED)	J5-4	P2 (LED)	J5-5	PS (LED)
1 or 2	0	1	12.95	High	Off	High	Off	High	Off
1 or 2	1	1	3.84	High	Off	High	Off	High	Off
1 or 2	2	1	6.49	High	Off	High	Off	High	Off
1 or 2	3	1	12.95	High	Off	High	Off	High	Off
2	4	2	25.5	Low	On	High	Off	High	Off
3 or 4	0	1	12.95	High	Off	High	Off	Low	On
3 or 4	1	1	3.84	High	Off	High	Off	Low	On
3 or 4	2	1	6.49	High	Off	High	Off	Low	On
3 or 4	3	1	12.95	High	Off	High	Off	Low	On
3 or 4	4	2 or 3	25.5	Low	On	High	Off	Low	On
3 or 4	5	4	38.25	High	Off	Low	On	Low	On
3 or 4	6	4	51	High	Off	Low	On	Low	On
4	7	5	62	Low	On	Low	On	Low	On
4	8	5	71.3	Low	On	Low	On	Low	On

Table 2- Power level indication

AUTO-CLASS FEATURE

Auto-class is a classification mechanism that allows a PD to communicate its effective maximum power consumption to the PSE. This enables the PSE to set its power budget according to the PD's actual maximum power requirement.

This new feature was introduced in the IEEE802.3bt standard to allow more efficient use of available power, as only the effectively used power needs to be budgeted. A Type 3 or Type 4 PD may optionally support Auto-class, and a Type 3 or Type 4 PSE may use it to optimize power management.

A PSE implementing Auto-class uses the first classification event to determine whether the PD supports Auto-class by monitoring whether the class current falls to the Class 0 current level. If so, the PSE can proceed with Auto-class measurement immediately after power-up, during which the PD is required to draw its maximum power throughout the bounded period using a sliding time window for power calculation.

To enable the Auto-class function during classification, connect the AUT pin to CGND (or use a shunt header/jumper to short J5 connector pins 7 and 8). Leave the pin open otherwise.

For more details please see [The benefits of using the Auto-class \(AUC\) feature in IEEE802.3bt PoE.](#)

ISOLATION

The IEEE802.3af/at/bt standards require that a Powered Device (PD) meet safety isolation standards by passing the electrical strength test specified in IEC 60950, sub-clause 6.2. The PEB9300BT board complies with these requirements by meeting or exceeding the 1500V impulse test, commonly referred to as the Hi-Pot Test or Isolation Test Voltage.

The PEB9300BT is provided with three mounting holes. MH1 and MH2 maintain 1500V isolation from the surrounding circuitry. The isolation area is highlighted with a 2mm white boundary, ensure that the heads of the mounting screws do not extend into this boundary. MH2 is internally connected to the metal body of the PoE IN and DATA OUT connectors. Maintain a minimum clearance of 2mm on all sides between the chassis and the PEB9300BT board.

LOAD SHARING

The PEB9300BT series supports parallel operation, allowing multiple boards to be connected together to increase overall output power while maintaining precise voltage regulation. When three PEB9300BT boards are operated in parallel, the load current is evenly distributed across the boards, providing higher combined output and improved thermal efficiency.

Infomart introduces a dedicated load-sharing solution, "TRISHUL", in which three PEB9300BT boards are connected in parallel (3 × 80W) to deliver up to 240W total output power. Actual performance may vary depending on the load profile and system operating conditions. This approach enables efficient power scaling without compromising performance or system reliability.

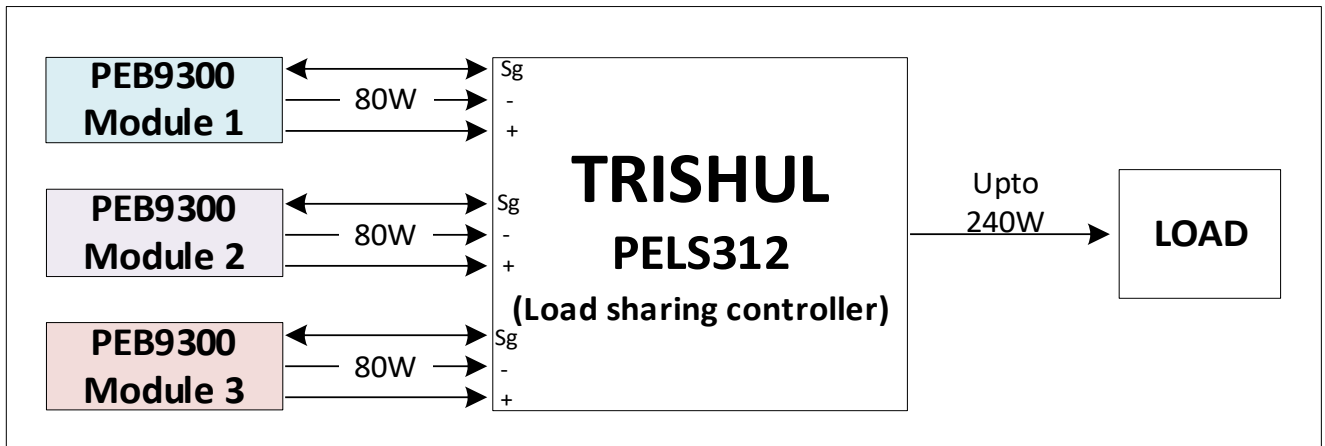

Figure 4- Load Sharing Control

This parallel configuration is ideally suited for high-power and mission-critical applications such as industrial automation controllers, computing platforms, LED display systems, and advanced PTZ camera solutions.

Please [contact Infomart technical support](#) for any further clarifications.

THERMAL MANAGEMENT

As with any power component, the PEB9300BT boards generate heat. It is important to ensure adequate ventilation and airflow during the design stage. The amount of heat generated by the PEB9300BT depends on the output load it is required to drive. The maximum ambient operating temperature is 70°C. The figure below shows the thermal performance of the PEB9300BT with a 51 V DC input. Thermal performance can be further improved by applying forced airflow cooling over the module.

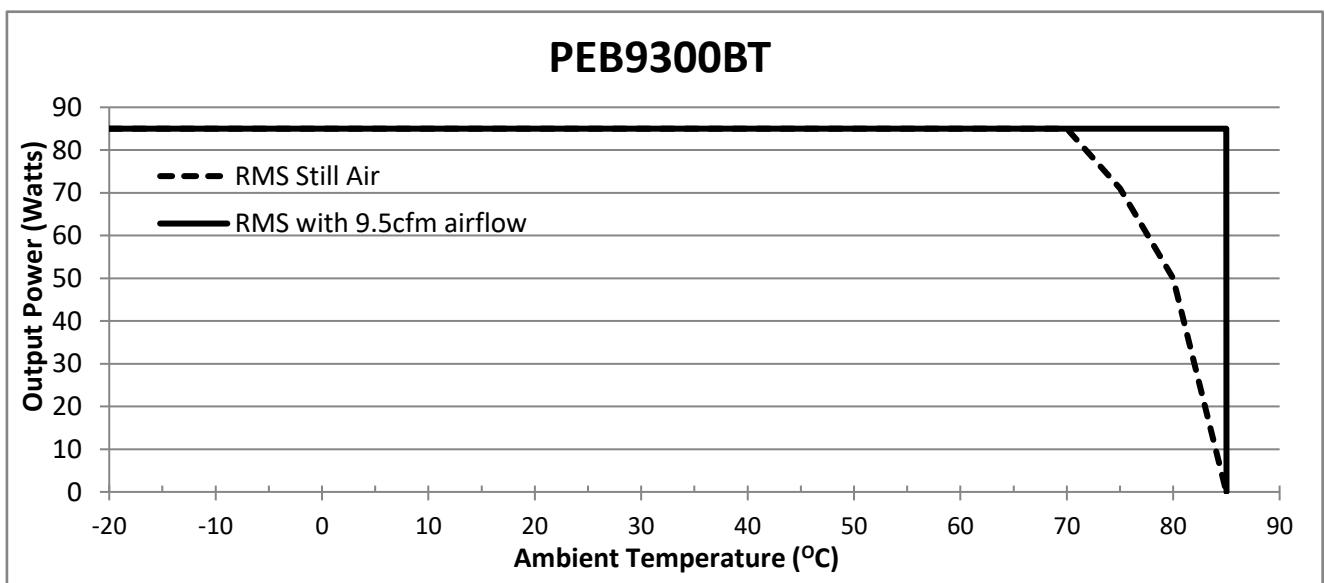
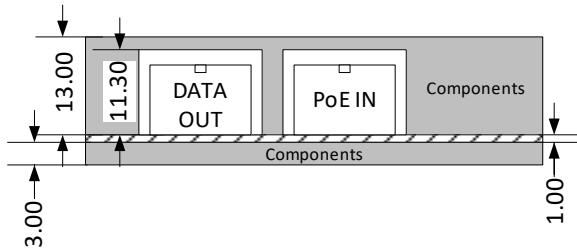

Figure 5- Thermal Performance profile at nominal V_{in}

PHYSICAL PACKAGE (All dimensions in mm)

Front View (± 0.50mm)



Top View (± 0.50mm)

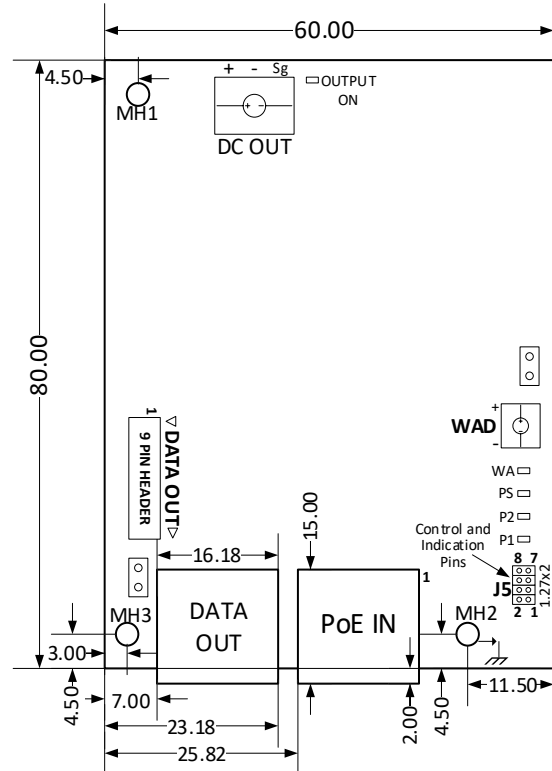

Note:

- M3 screw are recommended for MH1, MH2 and MH3.
- Mounting hole MH2 is internally connected to the metal shield of the PoE IN and DATA OUT connectors.
- Mounting holes MH1 and MH3 are non-conductive and free from components on the bottom side.

Figure 6- Mechanical Dimensions

ORDERING INFORMATION

Infomart Standard Configuration:

PEB93	XX	BT	J	J	W
Series	Voltage	IEEE Standard	POE In Connector	Data Out Connector	Wall Adapter
	12 = 12V out 20 = 20V out 24 = 24V out	IEEE802.3bt	RJ45	RJ45	

Table 3- Infomart Standard Configuration

OEM Customisation Options:

Additional connector and wall adapter customisation is available for large volume orders.

PEB93	XX	BT	X	X	Wall Adapter
Series	Voltage	IEEE Standard	POE In Connector	Data Out Connector	W= Populated N= NOT populated
	12 = 12V out 20 = 20V out 24 = 24V out	IEEE802.3bt	J = RJ45 H = Header	J = RJ45 H = Header D = Dual	

Table 4- OEM Customisation Options

Private labelling is available for orders of more than 10,000 units. Please [contact Infomart](#) for details.

ROHS, REACH and CONFLICT MINERALS COMPLIANCE

ROHS, REACH and Conflict Minerals compliance details are available on our website www.poweredethernet.com.

REVISION HISTORY

REVISION NUMBER	DESCRIPTION
24JR1	▪ New release
24LR1	▪ Updated IEEE802.3 POWER LEVELS AND CLASSES
25AR3	▪ Update in PRODUCT FEATURES
25BR4	▪ Update in PRODUCT FEATURES
25CR5	▪ Update in PHYSICAL PACKAGE
25GR6	▪ Update in DC OUTPUT CHARACTERISTICS and ORDERING INFORMATION
25KR7	▪ Update in PHYSICAL PACKAGE and ISOLATION
25LR8	▪ Update in ORDERING INFORMATION and LOAD SHARING section added

IEEE802.3 POWER LEVELS AND CLASSES FOR PoE POWERED DEVICES

IEEE Standard	Common Name	PD Class	PD/PSE Type	Max num. Of events	PD Power ¹	PSE Power ²	Wire pairs energised	AUC ³
802.3af	PoE	0	1	-	12.95W	15.4W	2	No Support
802.3af	PoE	1	1	1	3.84W	4W	2	No Support
802.3af	PoE	2	1	1	6.49W	7W	2	No Support
802.3af	PoE	3	1	1	12.95W	15.4W	2	No Support
802.3at	PoE+	4	2	2	25.5W	30W	2	No Support
802.3bt	PoE++	5	3	4	38.25W	45W	4	Optional
802.3bt	PoE++	6	3	4	51W	60W	4	Optional
802.3bt	PoE+++	7	4	5	62W	75W	4	Optional
802.3bt	PoE+++	8	4	5	71.3W	90W	4	Optional

¹ Min. power delivered to PD / Module input. Max. PD / Module output depends on operating conditions.

² Power delivered from the Power Sourcing Equipment (PSE) (switch or injector) at its output port.

³ Auto Class is supported. It is optional to enable or not.

**Infomart India Pvt. Ltd.**

Infomart Tech Park
99, 5th Cross, 5th Block, Koramangala
Bangalore – 560 095, India
Tel: +91 80 4111-7200
Email: pesales@infomartgroup.com

Infomart Technologies

Americas sales office
5904, South Cooper St. #104-96
Arlington, Texas, 76017, USA
Tel: +1 903-270-9090

Infomart India Pvt. Ltd. (Infomart®) products are sold subject to the standard terms and conditions of sale, as published at www.poweredethernet.com unless otherwise agreed on a written agreement. Infomart® reserves the right to make changes to any products herein, without further notice. The customer is responsible for its products and applications using Infomart® products, including compliance with all laws, regulations and safety requirements or standards, regardless of any support or applications information provided by Infomart®. “Typical” parameters which may be provided in Infomart® data sheets and / or in specifications can and do vary in different applications and actual performance may vary over time. Infomart® makes no warranty, representation or guarantee regarding the suitability of its products for any particular purpose, nor does Infomart® assume any liability arising out of the application or use of any product or circuit, and specifically disclaims any and all liability, including without limitation special, consequential or incidental damages. All operating parameters, including “Typical” must be validated for each customer application by customer’s technical experts. Infomart® products are not designed, intended, or authorized for use as a critical component in life support systems or any FDA Class 3 medical devices or medical devices with a same or similar classification in a foreign jurisdiction or any devices intended for implantation in the human body. Should Buyer purchase or use Infomart® products for any such unintended or unauthorized application, Buyer shall indemnify and hold Infomart® or and its officers, employees, subsidiaries, affiliates, and distributors harmless against all claims, costs, damages, and expenses, and reasonable attorney fees arising out of, directly or indirectly, any claim of personal injury or death associated with such unintended or unauthorized use, even if such claim alleges that Infomart® was negligent regarding the design or manufacture of the part. This document is subject to all applicable copyright laws and is not for resale and may not be altered in any manner. Infomart is a registered trademark of Infomart® (India) Pvt. Ltd. PoweredEthernet™ is a trademark of Infomart® (India) Pvt. Ltd.

