

## PRODUCT OVERVIEW

The PEM1500 series of power extraction modules, have complete compliance with the IEEE 802.3af Power-Over-Ethernet (PoE) standard, and are designed to extract power from CAT5 Ethernet cable when sourced by a IEEE 802.3af compliant Power Sourcing Equipment (PSE).

The PEM1500 series Powered Device (PD) modules provides full PoE signature and power classification as required by the PSE for granular power management.

Its high efficiency DC-DC converter provides a well regulated low noise and low ripple output with in-built overload and continuous output short-circuit protection.

The PEM1500 series provides a quick, easy, and low cost method for Ethernet equipment manufacturers to "PoE enable" their equipment, and removes the need for a local equipment power source, significantly reducing installation costs.

## PRODUCT FEATURES

- Remote shutdown, simple Aux. power
- Continuous short circuit protection
- 1500 Volt DC isolation (Input to Output)
- Overload protection<sup>1</sup>
- No external components required
- 13 watt output load<sup>2</sup>
- Compact package minimum PCB footprint
- 5V, 12V DC output voltage models
- IEEE 802.3af compliant
- IEEE Power Classification
- Wide input voltage (36V to 57V DC)
- RoHS compliant
- Low output ripple and noise
- Low cost



<sup>1</sup> If maximum power is exceeded, the PEM1500 will operate in over current mode and will auto recover when the over load condition is removed.

<sup>2</sup> In 12V model

PRODUCT SELECTOR					
Part Number	Marking	Output Voltage <sup>3</sup>	Efficiency <sup>4</sup> (%)	Power (Maximum) <sup>7</sup>	Feature
		(Volts DC)		(Watts)	
PEM1505A-42	5A	5	82	10	Without remote shutdown
PEM1512A-42	12A	12	84	12.95	Without remote shutdown
PEM1505C-42	5C	5	82	10	With built in remote shutdown
PEM1512C-42	12C	12	84	12.95	With built in remote shutdown

ABSOLUTE MAXIMUM RATINGS <sup>5, 6</sup>	
Supply Voltage (V <sub>CC</sub> )	0V – 57V DC
Storage Temperature (T <sub>S</sub> )	-25 °C ~ 100 °C
Output Voltage (V <sub>OUT</sub> )	0V to controlled output voltage (operating or non-operating)

INPUT CHARACTERISTICS					
Parameter	Symbol	Min.	Typ <sup>4, 5</sup>	Max.	Units
Input Voltage <sup>7</sup>	V <sub>IN</sub>	36	48	57	Volts
Under Voltage Lockout	V <sub>UVLO</sub>	30		36	Volts
Operating Temperature <sup>8</sup>	T <sub>OP</sub>	-20	25	70	°C
802.3af Power Classification <sup>9</sup>	Programmable Class 0, 1, 2, or 3				

DC OUTPUT CHARACTERISTICS					
Parameter	Symbol	Min.	Typ <sup>4, 5</sup>	Max.	Units
Line Regulation	V <sub>LNRG</sub>		0.2%		
Load Regulation	V <sub>LDRG</sub>		0.5%		
Output Ripple and Noise <sup>5</sup>	V <sub>RIP</sub>		80		mV p-p
Isolation Voltage	V <sub>ISOL</sub>			1500	V DC
Temperature Coefficient (Slope)	TC		100	300	ppm °C

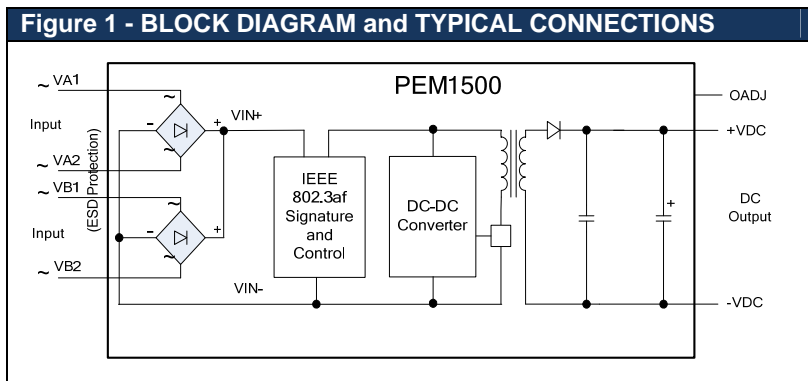

<sup>3</sup> Output voltage typical  $\pm 3\%$  at T<sub>A</sub> of 25°C with a nominal input voltage and rated output current.

<sup>4</sup> At nominal V<sub>in</sub> at 67% load

<sup>5</sup> All specifications typical are at T<sub>A</sub> of 25°C with a nominal input voltage and rated output current unless otherwise noted. These are meant as a design aid only and are indicative, and not guaranteed.

<sup>6</sup> Exceeding the absolute maximum ratings may cause permanent damage to the product. We do not imply functional operation under these conditions. These ratings assume free air flow.

<sup>7</sup> With minimum load 100mA

<sup>8</sup> Please see section 8: Heat Generation.

<sup>9</sup> Please see section 2: Powered Device Signature and Classification for more details.

## FUNCTIONAL DESCRIPTION

### 1. Inputs

The PEM1500 is compatible with all IEEE 802.3af compliant Power Sourcing Equipment (PSE) and supports the different power injection options of Data/Signal pair (Mode A) or Spare Pair (Mode B). See Figure 2 – Typical System Configuration. As per IEEE 802.3af, it is specified that the PSE does not apply power to the both outputs at the same time i.e. 4 pair injection. (Refer to IEEE802.3af standards for more information).

### Figure 2 – Typical System Configuration

In Mode A – Signal Pair injection, the signal lines carry both data and power. In Mode B – Spare Pair injection, the Signal pair carries only data, and the spare pair carries power.

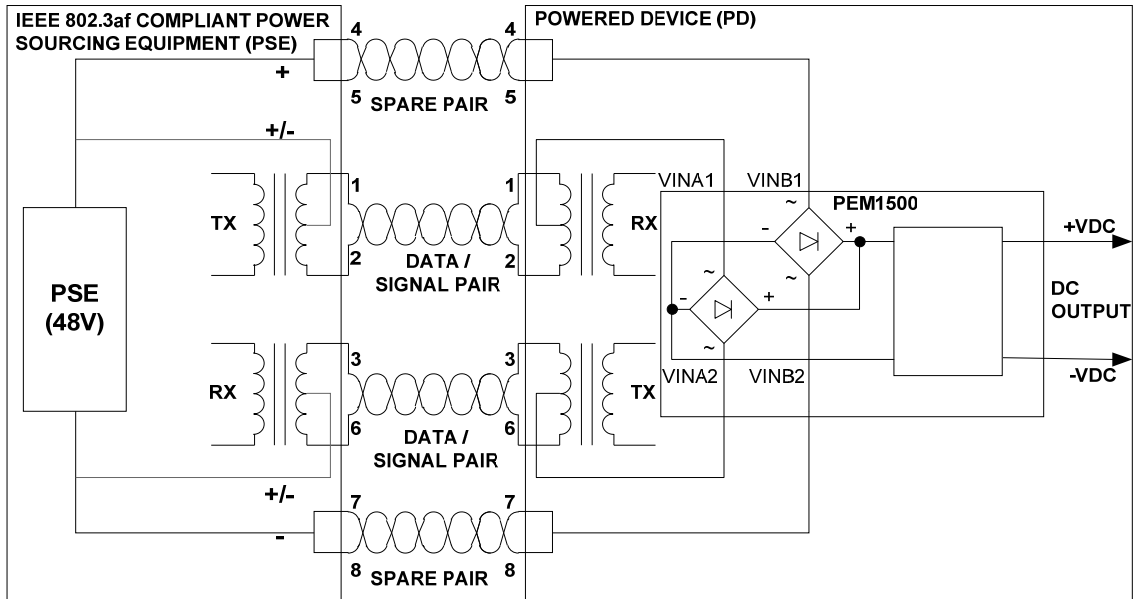

### 2. Powered Device (PD) Signature and Classification

When the PEM1500 is connected to a Cat 5e or greater Ethernet cable from an IEEE 802.3af compliant Power Sourcing Equipment (PSE), Endspan or Midspan, it will automatically present a Powered Device (PD) signature to the PSE, as and when requested. The PSE will then recognise that a PD is connected to that line and supply power.

To help in proper power level provisioning and improved power management, the IEEE 802.3af standard provides for PoE powered devices to inform the PSE the required power levels via a Class system. The classes are defined as per Table 1 below. The PEM1500 allows for programming the Class by placing a 1/16W or greater and 1% tolerance resistor detailed in Table 1.

Table 1 – Power Classification programming		
PoE Power Class	Required PD Power	1/16W or greater and 1% tolerance resistor between Pin 5 (CP1) and Pin 6 (CP2)
0	0.44W ~ 12.95W	Do not connect
1	0.44W ~ 3.84W	280kΩ
2	3.84W ~ 6.49W	143kΩ
3	6.49W ~ 12.95W	90kΩ
4	Reserved for 802.3at	Reserved

Never connect Pins 1, 2, 3 and/or 4, to Pins 5, and/or 6.

### 3. Isolation

IEEE802.3af section 33.4.1 calls for a Powered Device (PD) to meet safety isolation requirement by meeting the electrical strength test of IEC 60950 sub clause 6.2. Infomart's® PoweredEthernet™ PEM1500 modules meet or exceed 1500V impulse test. This is also referred to as 'Hi Pot Test', 'Flash Tested', 'Withstand Voltage', 'Proof Voltage', 'Dielectric Withstand Voltage' & 'Isolation Test Voltage'.

## FUNCTIONAL DESCRIPTION

### 4. Pin Connections

INPUT CONNECTORS (J1) (Maximum current 1A per pin)		OUTPUT CONNECTORS (J2) (Maximum current 1A per pin)	
1	VINA1. This pin connects to Ethernet cable spare pair (for Mode B PoE injection). Not polarity sensitive.	1	-VDC. The ground return for the +VDC output. (Internally connected to pins 2).
2	VINA2. This pin connects to Ethernet cable spare pair (for Mode B PoE injection). Not polarity sensitive.	2	-VDC. The ground return for the +VDC output. (Internally connected to pins 1).
3	VINB1. This pin connects to the output of the data transformer centre tap (for Mode A PoE injection). Not polarity sensitive.	3	OADJ. The output voltage can be adjusted from its nominal value, by connecting an external resistor from this pin to either the +VDC pin or -VDC pin. For more details please see 8.
4	VINB2. This pin connects to the output of the data transformer centre tap (for Mode A PoE injection). Not polarity sensitive.	4	NC Do not connect for PEM15xxA-42 RSD for PEM15xxC-42. This pin can be used for remotely shutting down the module from the target device. Please see 6.
5	CP1. Connect this pin only as per instructions in Table 1.	5	+VDC. This pin provides the regulated output from the DC/DC converter. (Internally connected to pin 6).
6	CP2. Connect this pin only as per instructions in Table 1.	6	+VDC. This pin provides the regulated output from the DC/DC converter. (Internally connected to pin 5).

To maintain isolation integrity, always connect respective input and output poles only via X or Y safety capacitor. Maintain isolation barrier on motherboard PCB as per physical package.

### 5. Connectors

The connectors used on the module are standard CMX125 series wafer or relay-mate-connectors. The matching header or cable housing is the CX-H125-06 fitted with CX-T125-F terminal pins.

Please visit Cheng Weei Technology Corporation website [www.cwe.com.tw](http://www.cwe.com.tw) for detailed purchase information on these connectors.

### 6. Auxiliary power supply using Remote Shut Down pin (RSD)

The PEM15xxC-42 series is featured with built in Remote Shut Down option, which can be used in case the host board need to shut down PEM15xxC-42. This feature is helpful with host boards having auxiliary power supply.

Using the remote shut down feature the designer can decide the priority of POE power or auxiliary power. For example, when the auxiliary power supply is live, the host board can shut down the PEM15xxC-42 output. For connections refer below figure 3.

To shut down the PEM15xxC-42 the host board needs to pull the RSD pin from Zero to High. When the RSD pin is activated, the output of the PEM15xxC-42 will switch off.

Under default conditions, the target device draws power from the PEM module via the Schottky diode D1. (D1 to be chosen so as to have a forward voltage drop of maximum +0.5V). Resistor R1 is used to increase the output voltage at pin +VDC so that the voltage drop due to D1 gets compensated and provides desired output to target device.

As a built in feature in PEM15xxC-42, whenever the auxiliary power supply is in an on-state and delivering the desired voltage, it pulls the RSD pin HIGH. The RSD in HIGH state shuts down the output of the PEM module internally. The auxiliary supplies power to the target device via Schottky diode D2. The PEM module will continue to stay in an internally off state as long as RSD pin is HIGH.

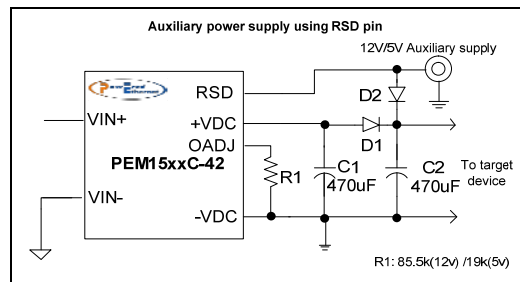

Figure.3

Similarly the RSD feature can be used to initiate a hardware reset by the host board based on SNMP. In this case, connect the RSD pin directly to the host board controller.

## 7. Gigabit Ethernet

The PEM1500 supports interface to a 10/100/1000Tx Gigabit Ethernet network. Contact Infomart for more details.

## 8. Output voltage adjust

The PEM1500 series has an ADJ pin, which allows the output voltage to be increased or decreased from its nominal value.

Value of Resistor between OADJ and +VDC	PEM1505 output	PEM1512 output
Open Circuit	5.0V	12.0V
Approximate Resistor Value in ( )	4.5V (15.8K)	11.0V (100K)
Approximate Resistor Value in ( )	-	9.0V (30K)

Value of Resistor between OADJ and -VDC	PEM1505 output	PEM1512 output
Open Circuit	5.0V	12.0V
Approximate Resistor Value in ( )	5.5V (18.6K)	13.0V (51K)
Approximate Resistor Value in ( )	-	13.5V (30K)
Approximate Resistor Value in ( )	6V (9.1K)	13.8V (24K)

Resistance value fixed here are indicative. Fine tuning is required to get the specified voltage depending upon the resistance of the wire.

Other values of resistors may be fitted to arrive at a custom voltage, however, a change of more than  $\pm 10\%$  from nominal is not recommend or permitted

## Figure 4 – PHYSICAL PACKAGE

All dimensions in mm and nominal unless stated otherwise.

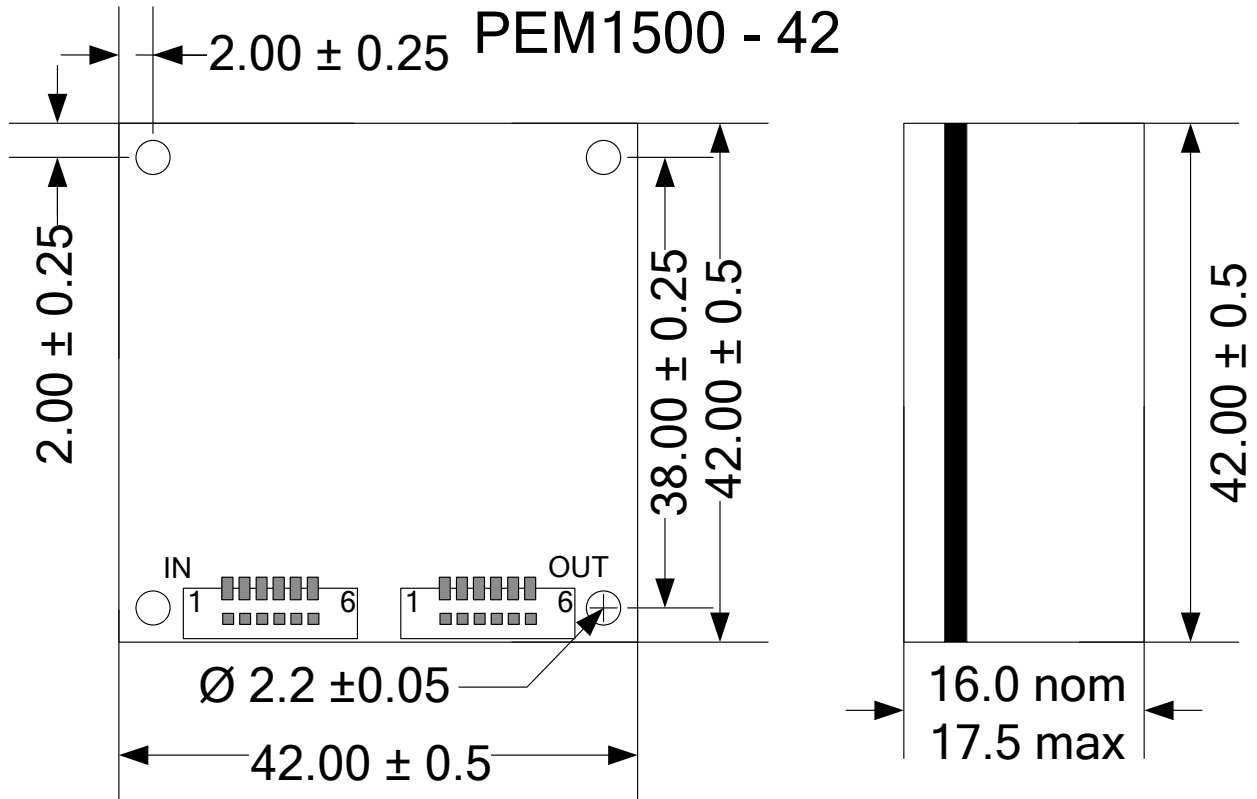

## THERMAL PROFILE

### 8. Heat Generation

As with any power component, the PEM1500 modules generate heat. It is important that adequate ventilation and airflow be taken into consideration at the design stage. The quantum of heat generated by the PEM1500 will depend on the output load it is required to drive. The maximum ambient operating temperature is 70°C. *Figure 4* below, shows the thermal performance of the PEM1500 with a nominal 48VDC input. The PEM1500 thermal performance can be improved by forced airflow cooling over the module and by using a heat sink (a) glued on to the output diodes using a thermal glue. The two methods can be combined.

**Figure 5 – Thermal Performance profile at nominal  $V_{in}$**

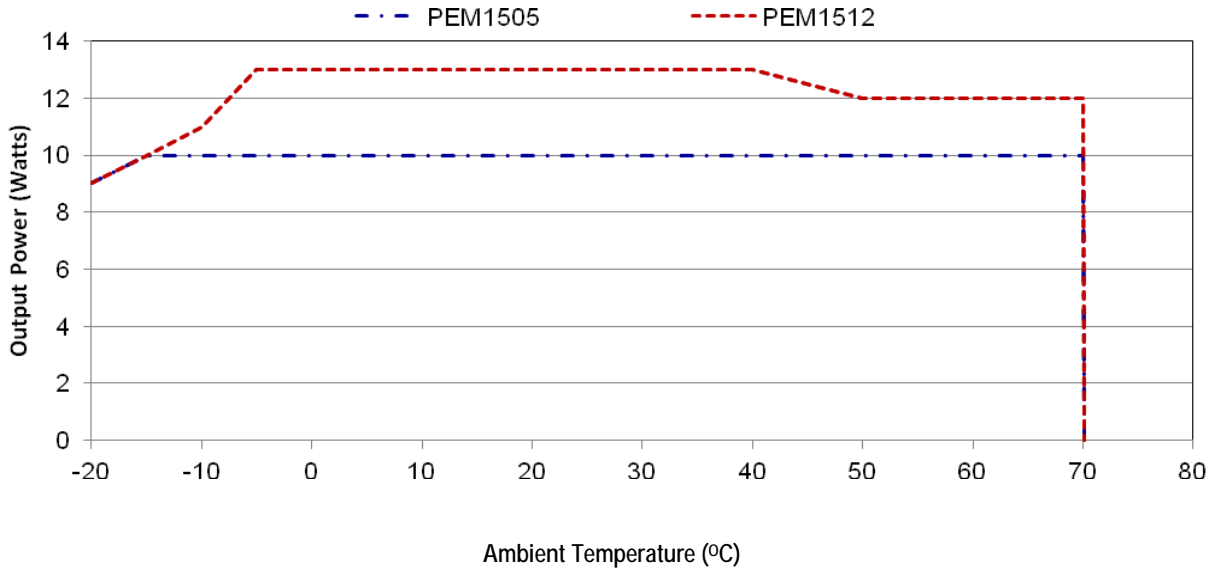

## APPLICATION NOTES

Power Over Ethernet (PoE) is a technology for wired Ethernet, the most widely installed local area network technology in use today. PoE allows the electrical power necessary for the operation of each end-device to be carried by data cables along with the data, rather than by separate power cords. Thus, it minimizes the number of wires used to install the network, resulting in lower cost, less downtime, easier maintenance and greater installation flexibility.

The IEEE standard governing PoE is IEEE802.3af. Compliance with this standard ensures inter-operability between devices.

The PEM1500 series modules offering a modular solution, incorporating full IEEE802.3af compatibility signature to the PSE and isolated on-board DC/DC converter. The PEM1500 series are ideal modular system blocks allowing manufacturers of Ethernet equipment to “PoE enable” their equipment with minimal effort and cost. The PEM1500 modules series offer simple and quicker product development, maximising return on investment.

PEM1500 can be powered using a user designed power supply which has adequate thermal and over-current protection. It is strongly recommended that only IEEE802.3af compliant power supply equipment be used to prevent damage to the module, which lacks output stage thermal protection .

**ESD Protection:** It is required that the system designer must provide ESD protection such as an SMAJ58A (uni-directional) or SMAJ58CA (bi-directional) TVS diode at the PEM1500 input(s) to prevent damage from over-voltage surges and for system EMC compliance.

### APPLICATION AREAS

- Security and alarm systems,
- Access control systems
- IP Cameras
- Displays
- Public address systems
- Wireless access point
- Environmental control
- Telemetry
- Remote environmental monitoring

**Figure 6 – Typical PoE System Configuration**

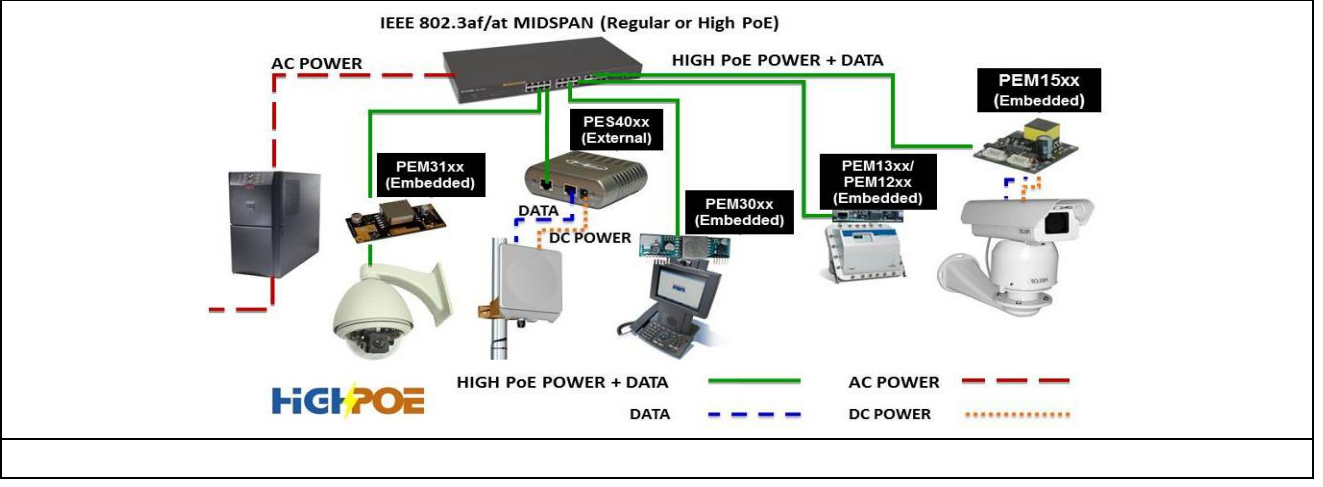

**Infomart Asia Pacific Pte. Ltd.**

1, North Bridge Road #19-04  
High Street Centre  
Singapore 179094  
Tel : +65 6225-6500

[pesales@infomartgroup.com](mailto:pesales@infomartgroup.com)

**Infomart India Pvt. Ltd.**

Infomart Tech Park  
99, 5<sup>th</sup> Cross, 5<sup>th</sup> Block, Koramangala  
Bangalore – 560 095, Karnataka  
India  
Tel : +91 80 4111-7200

[pesales@infomartgroup.com](mailto:pesales@infomartgroup.com)

**Infomart Technologies**

Americas sales office  
5904, South Cooper St. #104-96  
Arlington, Texas, 76017, USA  
Tel : +1 (682) 234-4600

Infomart® reserves the right to alter or improve the specification, internal design or manufacturing process at any time, without notice. Please check with your distributor or visit our website to ensure that you have the current and complete specification for your product before use. © Infomart Asia Pacific Pte. Ltd. All rights reserved. This publication, in full or in part, may not be copied, transmitted or stored in a retrieval system, or reproduced in any way including, but not limited to, magnetic, digital, photographic, photocopy, magnetic or other recording means, without prior written permission from Infomart Asia Pacific Pte. Ltd. Infomart is a registered trademark of Infomart® (India) Pvt. Ltd. PoweredEthernet™ is a trademark of Infomart (India) Pvt. Ltd.