

Any Power over Ethernet (PoE) module will generate Electromagnetic Interference (EMI) both radiated and conducted, during its operation, but since it is just one component within your overall equipment/system, it is extremely difficult for Infomart® to comment on what exact methods and components will be required for meeting the EMI requirements of the EN55022 (CISPR22) or EN55024 or EN61000 test standards.

There are many methods of reducing EMI from utilizing proper PCB layout, metal chassis or EMI suppression plates, components, and filtering.

This application note attempts to describe some of the filtering techniques which can be used for EMI suppression. These techniques may be used in combination to achieve desired results. For the purposes of this application note, the PoweredEthernet™ PEM1312 is being used as a representative POE-PD module. The PEM modules do feature some built-in EMI filtration.

1a. EMI filtration using safety capacitor.

Figure 1 (below) shows connections for EMI tuning by using a safety capacitor (C2) between the primary and secondary ground planes. It is important for the capacitor to maintain a safety isolation voltage. For example X2 or X1 safety capacitors can be used. For compact applications 2KV DC multi-layer ceramic capacitors can be used. The exact capacitance values will have to be tuned by the system designer.

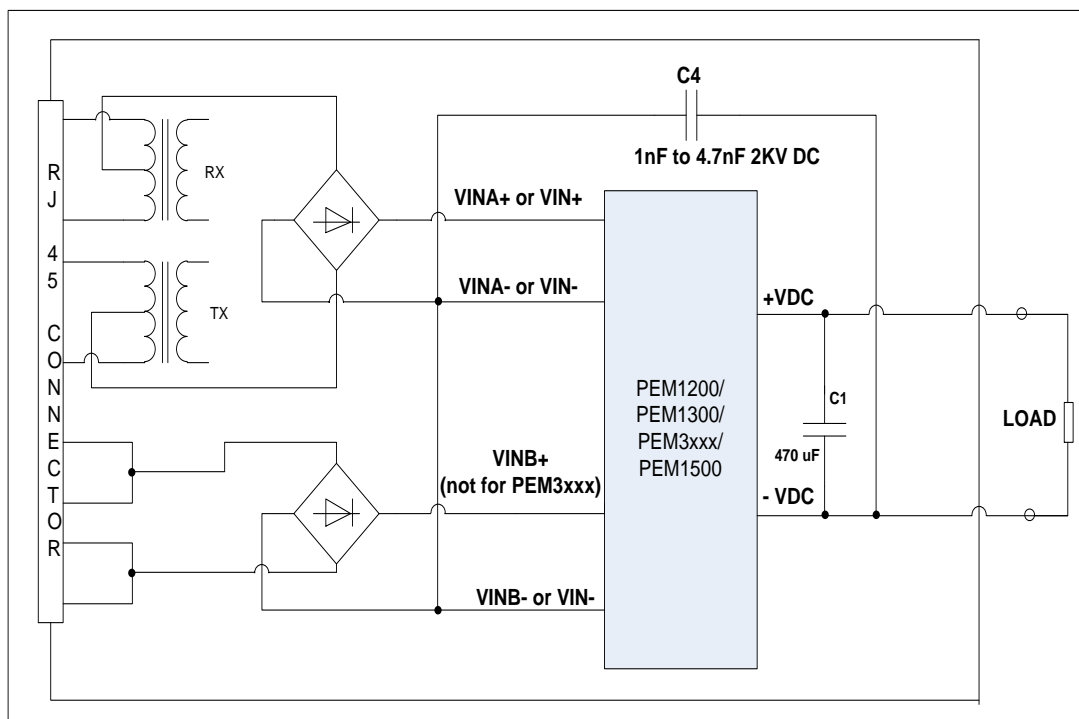

Figure 1. EMI filtration using safety capacitor

1b. EMI filtration using EMI and EMO pins only for PEM3000 and PEM3100 series.

Figure 2 (below) shows connections for EMI tuning by using EMI and EMO pins which are internally connected across the switching transformer. It is important for the capacitor to maintain a safety isolation voltage. For example X2 or X1 safety capacitors can be used. For compact applications 2KV DC multi-layer ceramic capacitors can be used. The exact capacitance values will have to be tuned by the system designer. Example: B32921C3104M-Metal poly film capacitor.

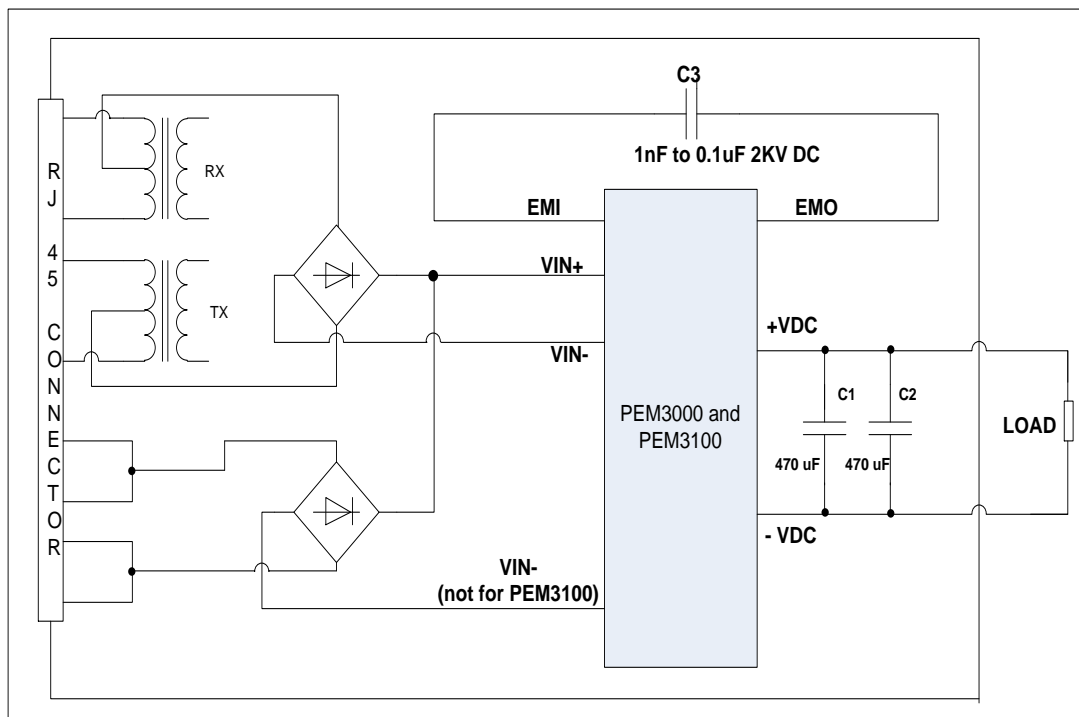

Figure 2. EMI filtration using EMI and EMO pins only for PEM3000 and PEM3100 series

2. Input chip bead filter

EMI, especially conducted emission can be reduced by using chip bead filter connected in series on each of the PoE input lines.

An example is shown in Figure 3 (below) using MURATA part number BLM15AX221SN1. The bead features nominal impedance 220R at 100MHz, DC resistance of 180mΩ and current capacity of 580mA. Please check the latest manufacturer datasheet for correct ratings. Chip bead filters of various impedance can be used to tune and suppress the EMI.

For increased suppression, multiple chip bead filters can be used in series on each PoE input line.

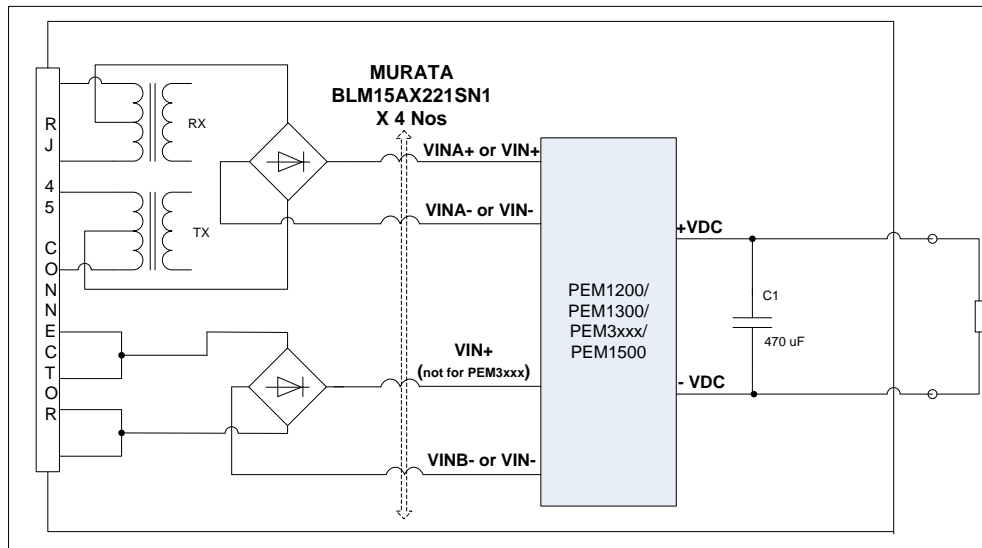

Figure 3. Chip bead filter

3. Common mode filters

This method uses Common mode filters to reduce the EMI. The connection diagram shown in Figure 4 (below). It is recommended that the input common mode filters be placed after the SMAJ58A TVS diode protection.

Input side filters L1 and L2 should be rated for 100VDC and at least 450mA current for IEEE 802.3af modules such as the PEM1200 and PEM1300 series and for at least 750mA current for IEEE802.3at applications such as the PEM3000 and PEM3100 series modules.

The output side filter (L3) should have a current rating which will be able to withstand a short-circuit between the POE PD module and the host board.

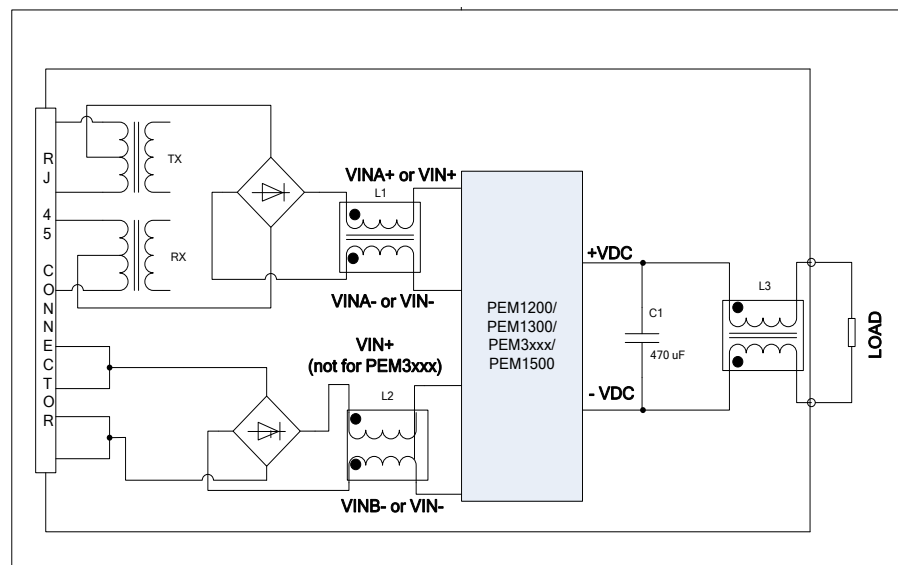

Figure 4. Common mode filters

4. Ground planes filtration

A very effective method of EMI suppression is with the use of ground planes. In addition to the primary and secondary ground planes of the PoE PD module, Figure 5 below introduces the concept of “Data Ground or F Ground” which uses the grounding provided by use of a metal jacket RJ-45 connector and STP Cat-5 or Cat-6 cabling.

EMI filtering can be achieved by using high voltage capacitors and RC networks as depicted in the schematic (Figure 5) below.

The primary or secondary ground planes of the POE-PD (pins 2 and 4, or on PEM13xx and PEM12xx) can also be connected to the metal jacket of the RJ45 connector (data ground) but the system designer must use a X2 safety or 2KV DC capacitors of 1nf to 4.7nf between each of the ground planes to maintain isolation and safety.

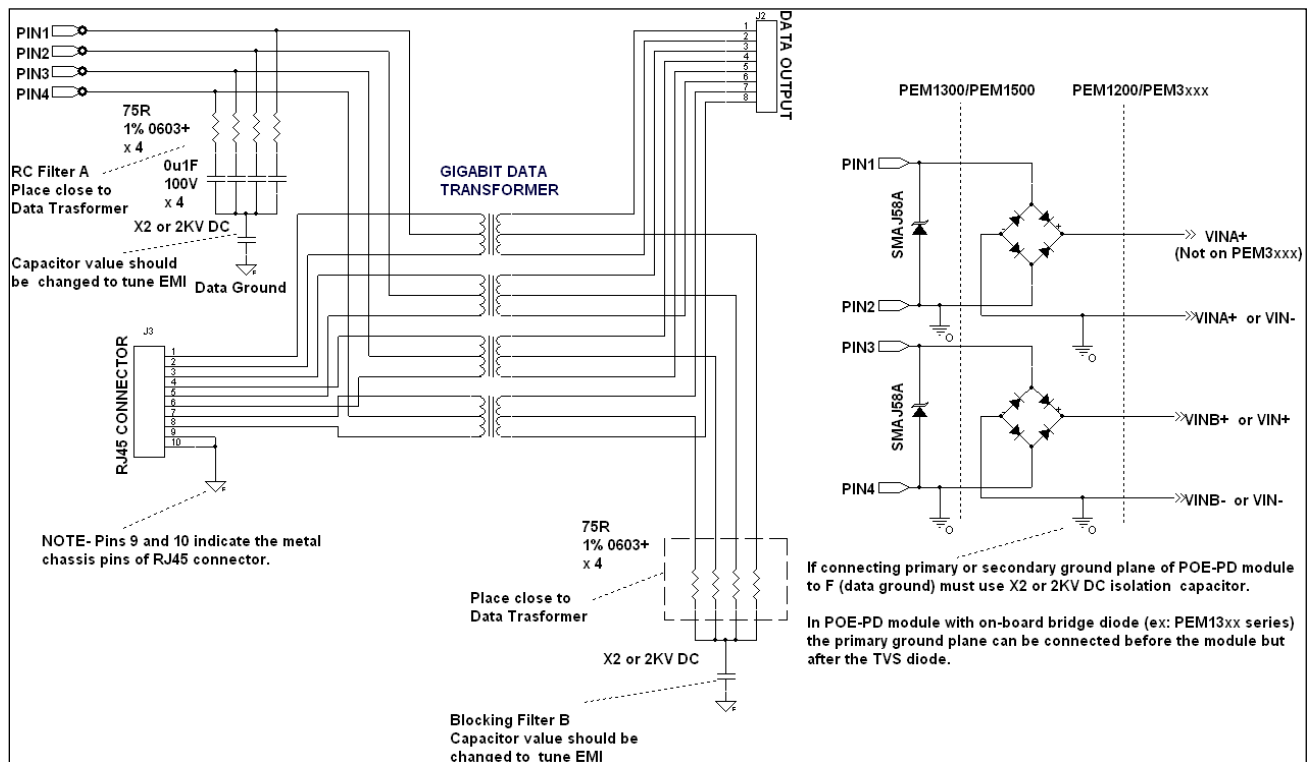

Figure 5– Ground planes filtration

In case the system designer is using 10BaseT or 100BaseT Ethernet, it is strongly recommended the RC Filter A on the POE connections to the module are still used. i.e. 2 x RC from the data transformer and 2 x RC from the spare pair. The Blocking Filter B, will be reduced to 2xResistors.